

QM Remote Cycle™ Battery Timer Remote Actuator



**Self-powered Series 94
electric actuator with open/close
timer**

Standard Features

- Engineered resin enclosures rated Type 4X with stainless steel trim
- On/off switch
- 12 VDC rechargeable battery
- Adjustable open and interval time via dip switches
- Visual position indication
- Manual override
- 1,100 cycles from a fully charged battery*
- Perfect for remote areas

*70 Degrees F



**QM Remote Cycle™ w/ Series 94
Actuator & Type-21 Ball Valve**



**QM Remote Cycle™ w/ Series 94
Actuator & Type-57 Butterfly Valve**

QM Remote Cycle™ Battery Timer Remote Actuator

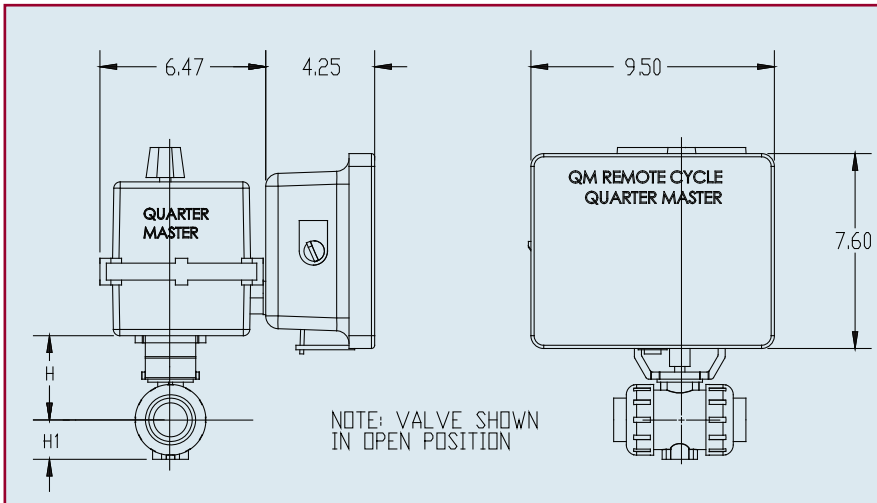

QM Remote Cycle™
Series 94 Electric Actuator
on Type-21 Ball Valve

Dimensions (in.)

| Size | H | H1 |
|-------|------|------|
| 1/2 | 2.76 | 1.14 |
| 3/4 | 3.01 | 1.38 |
| 1 | 3.29 | 1.54 |
| 1-1/4 | 3.64 | 1.85 |
| 1-1/2 | 3.98 | 2.17 |
| 2 | 4.43 | 2.60 |

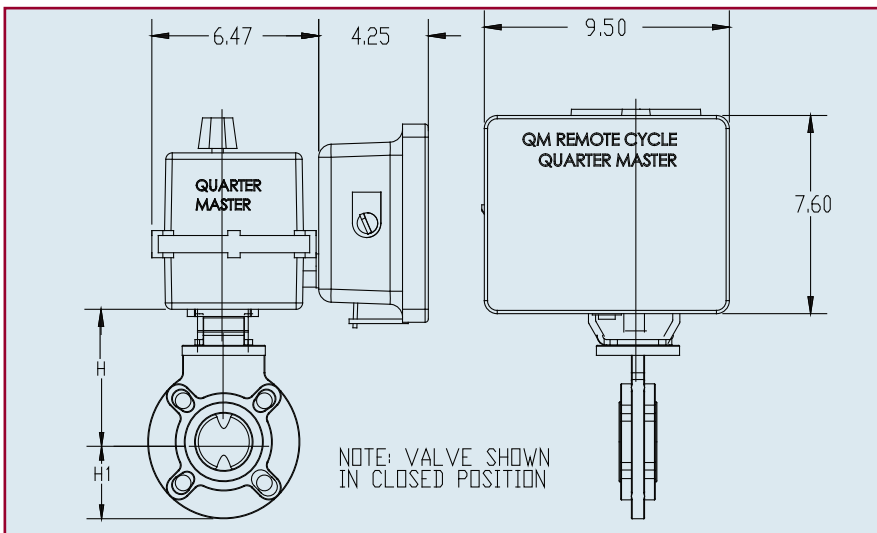

QM Remote Cycle™
Series 94 Electric Actuator
on Type-57P Butterfly Valve

Dimensions (in.)

| Size | H | H1 |
|-------|------|------|
| 1-1/2 | 5.51 | 2.95 |
| 2 | 5.75 | 3.27 |
| 2-1/2 | 6.18 | 3.66 |
| 3 | 6.46 | 3.94 |
| 4 | 7.16 | 4.53 |