

Series 19 SMART Modulating Multiturn Electric Actuator User Manual



Description

The Series 19 SMART modulating multiturn electric actuator features a reversing motor with multi-voltage capabilities; 95vac-265vac (50/60Hz) or 24 Vac/Vdc, an OLED Screen, an internal heater, positioner, transmitter, alarm/fault contacts, a NEMA Type 4X enclosure, manual override, visual flat disc position indication, LED Indicator (Open/Close/Alarm), ISO mounting, and 2M flying leads. The alarm/fault contacts are SPST and rated for 0.1A @250 Vac/0.5A@30 Vdc, and are factory calibrated.

Cover removal is NOT required for installation, and will void warranty!!

Additional options are NOT available for this model

Electrical Requirement

WARNING: Do not open actuator cover as warranty will be void!!

Model Number	Torque (in/lbs)	95 - 265 Vac		24 Vac/24 Vdc		Cycle Time per Revolution (Seconds)	Weight (Pounds)
		Amp Draw	Duty Cycle	Amp Draw	Duty Cycle		
S20MTHC1C3W	177	N/A	N/A	0.96	75%	4 seconds	1.7
S50MTHC1C3W	442	0.24	70%	1.2	75%	16 seconds	3.5

NOTE: Amp rating is considered running.
Duty cycles are for ambient temperature (73°F)

The Series 19 electric actuator has a sealed cable gland with 2M flying leads. The electrician is required to make field connections as per the wiring schematic shown in this manual for model numbers and voltages listed above. The electrician is responsible for following all and any, local and/or Agency wiring practices.

Note: *Not all wires provided will be used.*

Heater is internally wired and operational as long as actuator is powered.

Size 20 ONLY

Size 20 is specific to accept only voltage or current as a control signal/loop

- NOTES:
1. NOT ALL WIRES FROM FLYING LEADS ARE USED
 2. RED AND BLUE ARE POWER SUPPLY
 3. GREY AND WHITE ARE CONTROL SIGNAL INPUT
 4. BROWN AND WHITE ARE TRANSMITTER OUTPUT
 5. 10K RESISTOR SHALL BE USED FOR VOLTAGE TRANSMITTER, OR 250Ω RESISTOR FOR CURRENT TRANSMITTER
 6. USER CAN SET "NO CONTROL" DEFAULT POSITION IN FIRMWARE SETTINGS (FAIL IN PLACE, OPEN, CLOSE) FOR 4-20mA, 1-5V, AND 2-10V CONTROL SIGNAL. STANDARD IS FAIL IN PLACE. THIS SETTING IS NOT POSSIBLE IF USING A CONTROL SIGNAL OF 0-20mA, 0-5V, OR 0-10V
 7. HEATER IS INTERNALLY WIRED & OPERATIONAL AS LONG AS ACTUATOR IS POWERED

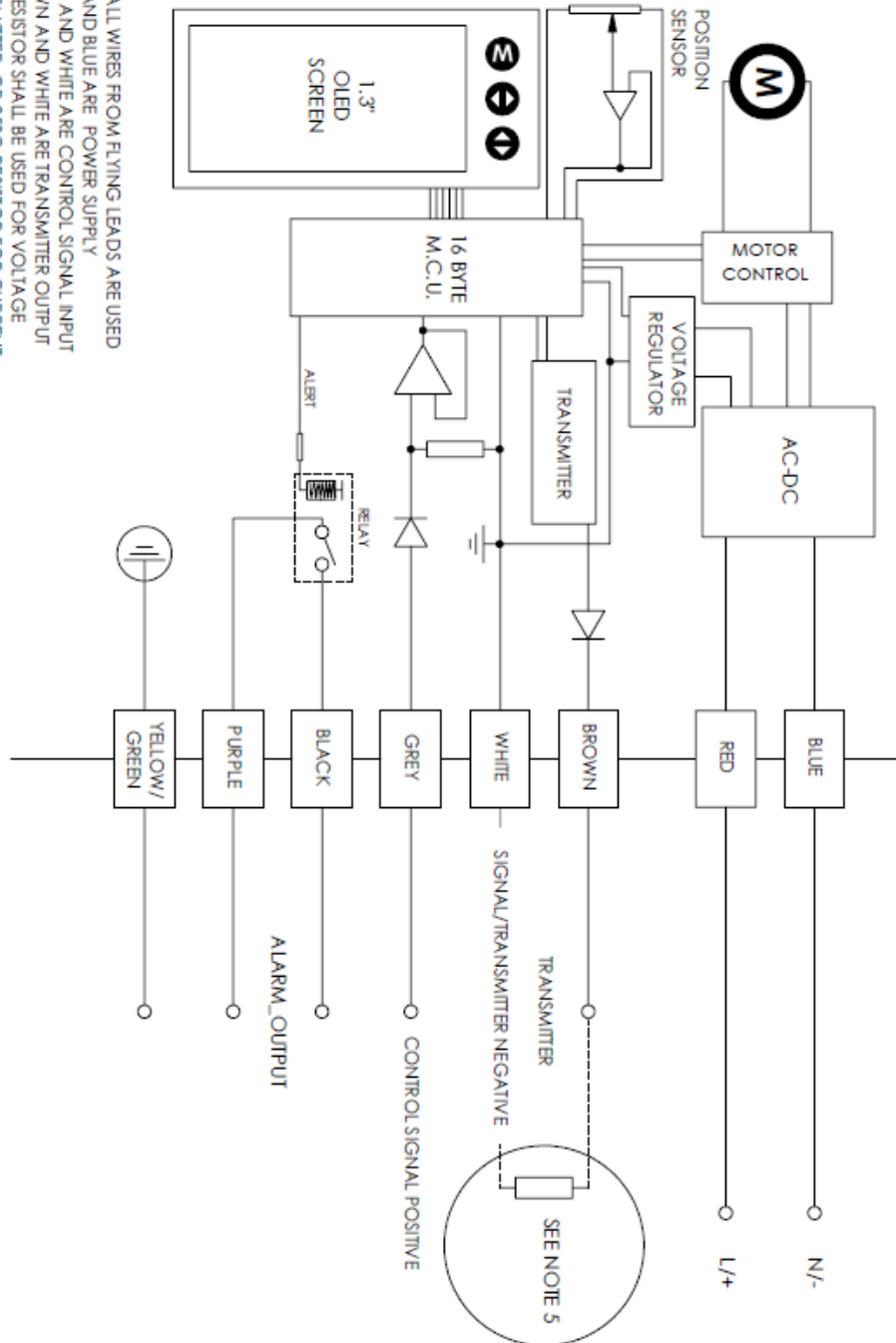

Size 20 will be labelled specifically as a voltage or current control signal/loop, and cannot be changed via onboard firmware. If a different control signal/loop is required, then another unit with the specific control signal/loop must be used.

Size 50

Size 50 can be calibrated for EITHER a voltage or a current control signal/loop via onboard firmware. Please contact the factory for instructions.

- NOTES:
1. NOT ALL WIRES FROM FLYING LEADS ARE USED
 2. RED AND BLUE ARE POWER SUPPLY
 3. PURPLE AND WHITE ARE VOLTAGE CONTROL SIGNAL,
 4. ORANGE AND WHITE ARE VOLTAGE TRANSMITTER
 5. GREY AND WHITE ARE CURRENT CONTROL SIGNAL, BROWN AND WHITE ARE CURRENT TRANSMITTER
 6. 10K RESISTOR SHALL BE USED FOR VOLTAGE TRANSMITTER, OR 250Ω RESISTOR FOR CURRENT TRANSMITTER
 7. USER CAN SET "NO CONTROL" DEFAULT POSITION IN FIRMWARE SETTINGS (FAIL IN PLACE, OPEN, CLOSE) FOR 4-20mA, 1-5V, AND 2-10V CONTROL SIGNAL. STANDARD IS FAIL IN PLACE. THIS SETTING IS NOT POSSIBLE IF USING A CONTROL SIGNAL OF 0-20mA, 0-5V, OR 0-10V
- HEATER IS INTERNALLY WIRED & OPERATIONAL AS LONG AS ACTUATOR IS POWERED

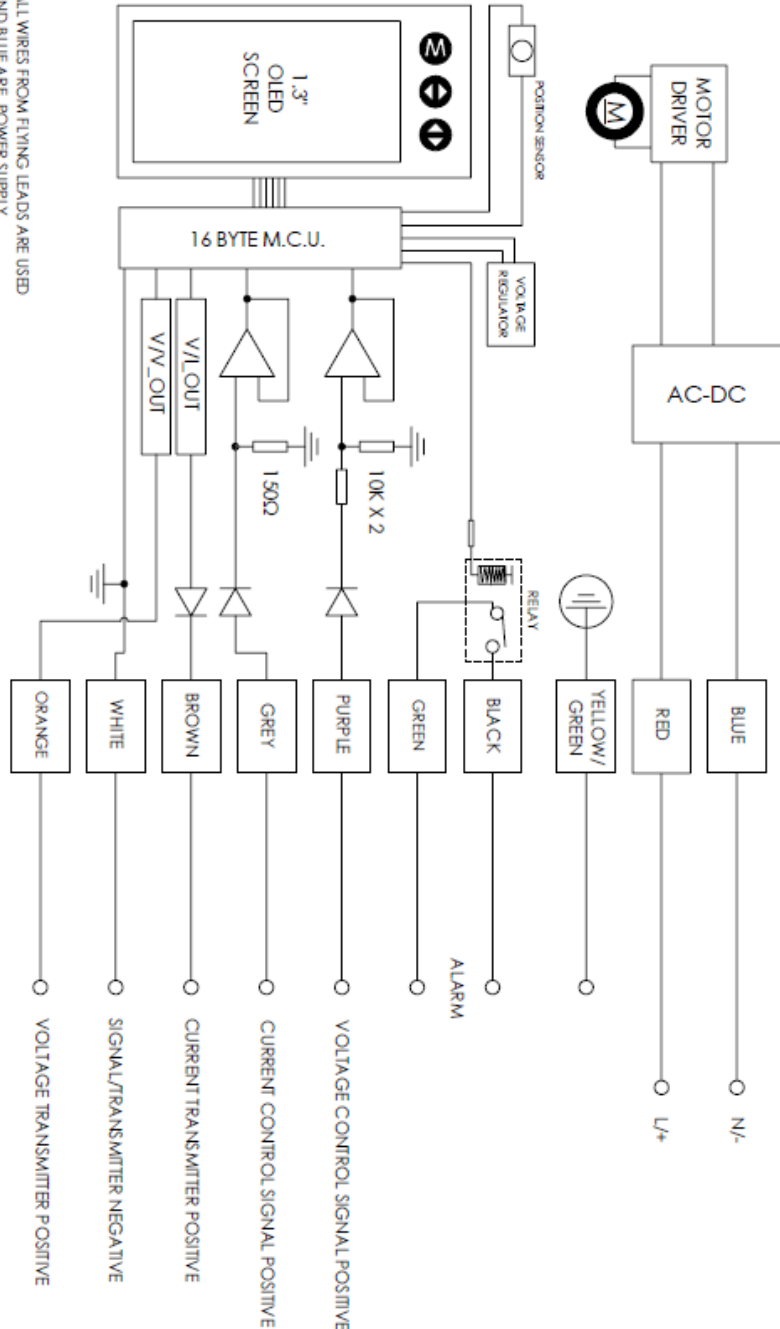

LED visual indicator is green for open, red for closed, or blue for alarm condition. Alarm condition could be a motor fault, valve jam, etc.

Need more information? Download a complete IOM at our website. www.asahi-america.com

Manual Override Operation

Remove manual override Hex Key from storage position located on the bottom of actuator, which is secured by SS clips. To operate the manual override, insert hex key into hex socket located on top of actuator and rotate to manually cycle valve (CCW to open, CW to close). **Manual override operation should always end with the valve in the closed position.** When finished using the manual override it is imperative to remove the hex key and place it back into storage on actuator base, making sure that it “clicks” into the locking position.

CAUTION: The manual override should only be used when there is no power applied to actuator. When power is restored the actuator will automatically resume normal operation. **Do not exceed the number of 360° turns specified from close to open as this will exceed the calibration range and the unit will not operate properly.**

Turns from Close to Open

Valve Size	Valve Type	Amount of Turns	Valve Type	Amount of Turns
½”	T-14 Diaphragm	3.25	Gate	N/A
¾”	T-14 Diaphragm	3.25	Gate	N/A
1”	T-14 Diaphragm	3.25	Gate	N/A
1 ¼”	T-14 Diaphragm	3.25	Gate	N/A
1 ½”	T-14 Diaphragm	4.25	Gate	5.25
2”	T-14 Diaphragm	5.25	Gate	5.25
2 ½”	T-14 Diaphragm	6.25	Gate	N/A
3”	T-14 Diaphragm	6.25	Gate	6.25
4”	T-14 Diaphragm	6.25	Gate	6.25

Local Controls Operation

The actuator can be locally controlled and driven to the open or closed position via OLED screen and push buttons. This simple procedure is detailed below.

Press and hold the “↓” button for 3 seconds. “K3” will flash in the top right hand corner and the unit will ask for a password. At this time, the password of “111” can be entered with “↓” selecting numbers and “↔” selecting the field. Once password is entered, press the “M” button to enter manual mode. The actuator can now be opened and closed via the push buttons. Press the “↓” button to OPEN the actuator. Press the “↔” button to CLOSE the actuator. To exit manual mode, press the M button or wait approximately 120 seconds and the manual mode will time out and exit. The actuator will not respond to control signals from the PLC until taken out of manual mode.

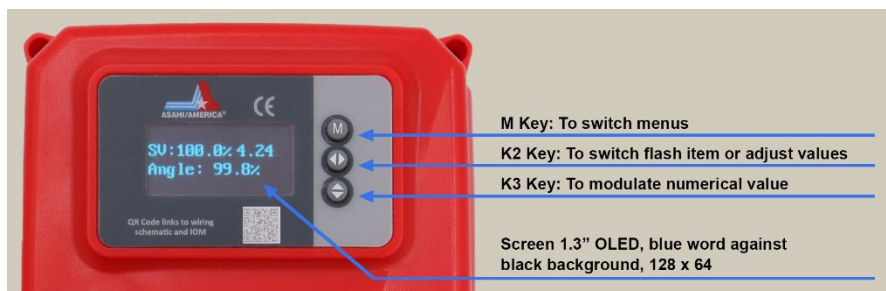

Need more information? Download a complete IOM at our website. www.asahi-america.com