

TYPE-C GATE VALVE WITH SERIES 19 MULTITURN **SMART** MODULATING ELECTRIC ACTUATOR



Standard Features (Sizes 1/2" - 4")

- **Compact:** Perfect for OEM and skid manufacturers
- **OLED Screen:** Displays valve position, alarms (such as an over torque condition)
- **Push Buttons:** Used to calibrate/adjust end positions, local controls
- **Multi-voltage:** 95 VAC to 265 VAC, 24VAC/VDC
- **Motor:** Reversing, brushless DC motor
- **Gear Train:** Permanently lubricated steel gears
- **Corrosion Resistant Enclosure:** NEMA 4X PC/PET enclosure with stainless steel trim
- **ISO mounting configuration**
- **Electrical Connection:** NEMA 4X cable gland with two-meter cable
- **Visual Position Indication:** Flat disc position indicator
- **LED Position Indication:** RED closed, GREEN open, BLUE fault
- **Manual Override:** Manually cycle valve via electroless nickel-plated hex key
- **Auxiliary Contacts:** Open and closed dry contacts rated 0.1 Amp @ 250 VAC, 0.5 Amp @ 30 VDC
- **Alarm Contact:** Dry contact rated 0.1 Amp @ 250 VAC, 0.5 Amp @ 30 VDC for alarm status (over torque, as an example)
- **QR Code:** Links to user manual; includes wiring schematic
- **Space Heater:** Internally wired to limit condensation
- **CE Compliant:** All actuators are CE labeled and compliant
- **75% Duty Cycle:** Extended duty cycle is ideal for high cycling applications
- **Simple Wiring:** Wiring technique is the same for all voltage units
- **Local Controls:** Used with OLED and push buttons, a user can locally open or close units via password

Specifications

Motor Type:	Reversing, brushless DC
Sizes:	S50 for 1-1/2" - 4" gate valves
Torque:	442 in-lbs
Voltage:	95 VAC to 265 VAC multi-voltage
Amp Draw:	0.24 Amp for S50
Max Ambient Temp:	150° F

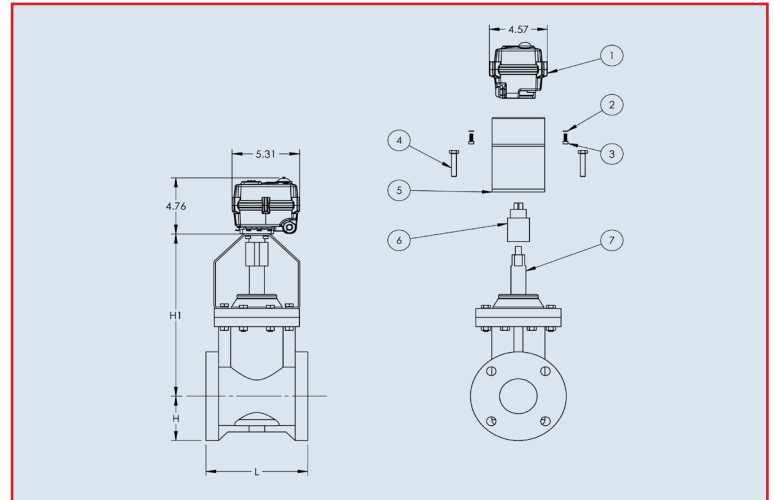

Dimensions (inch)

Size	1-1/2"	2"	3"	4"
H	2.50	3.00	3.75	4.5
H1	9.00	10.46	14.06	15.74
L	6.50	7.01	7.99	9.02
MODEL	S50MT	S50MT	S50MT	S50MT

Engineering Data

Size	Model	Torque (in/ lbs)	95-265 VAC		Cycle time (seconds)*	Weight (lbs)
			Amp Draw	Duty Cycle		
1-1/2"	S50MTHC1C3W	442	0.24	75%	92	11.2
2"	S50MTHC1C3W	442	0.24	75%	92	13.8
3"	S50MTHC1C3W	442	0.24	75%	156	20.2
4"	S50MTHC1C3W	442	0.24	75%	156	29.8

Size	Model	Torque (in/ lbs)	24 VAC/VDC		Cycle time (seconds)*	Weight (lbs)
			Amp Draw	Duty Cycle		
1-1/2"	S50MTHC1C3W	442	1.2	75%	84	11.2
2"	S50MTHC1C3W	442	1.2	75%	84	13.8
3"	S50MTHC1C3W	442	1.2	75%	100	20.2
4"	S50MTHC1C3W	442	1.2	75%	156	29.8

Amp draw is considered locked rotor

*Cycle times are approximate

Duty cycle shown for ambient temp (73° F)

TYPE-C GATE VALVE WITH SERIES 19 MULTITURN **SMART** MODULATING ELECTRIC ACTUATOR

Wiring Diagram

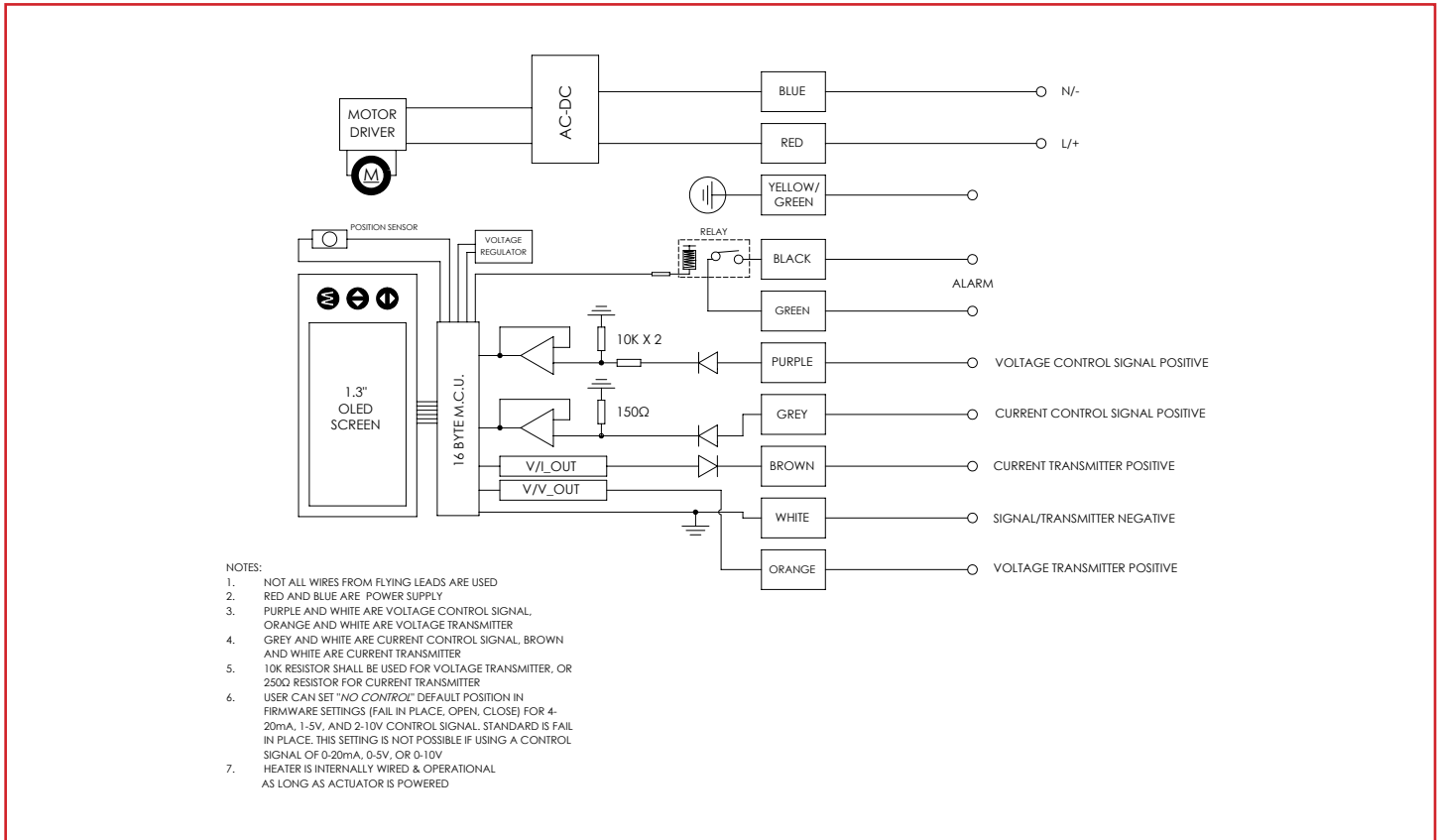

Sample Specifications

All Series 19 SAV smart modulating multiturn electric actuators shall have a brushless DC motor that accepts multiple voltages, permanently lubricated steel gears, NEMA 4X PC/PET enclosure with stainless steel trim, visual position indication, ISO 5211 valve mounting platform, manual override, and be CE compliant. Standard features shall include a heater, transmitter, field selection of various control signals, field selection of fail position (upon loss of control signal), one set of dry contacts for alarm reporting, LED indicator for position and alarm conditions, an OLED screen with push buttons, local controls, and a QR code that links to its user manual and wiring schematic.

