

# TYPE-14 DIAPHRAGM VALVE WITH SERIES 19 SMART MODULATING ELECTRIC ACTUATOR (95-265 VAC)

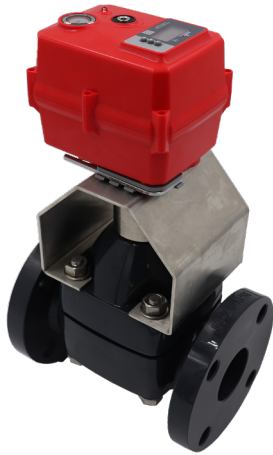

## Specifications

<b>Motor Type:</b>	Reversing, brushless DC
<b>Sizes:</b>	S50 for 1/2" – 4" diaphragm valves
<b>Torque:</b>	442 in-lbs
<b>Voltage:</b>	95 VAC to 265 VAC multi-voltage
<b>Amp Draw:</b>	0.24 Amp for S50
<b>Max Ambient Temp:</b>	150° F

## Standard Features (Sizes 1/2" – 4")

- **Compact:** Perfect for OEM and skid manufacturers
- **OLED Screen:** Displays input command, position status, alert conditions
- **Push Buttons:** Used to calibrate, local controls
- **Multi-voltage:** 95 VAC to 265 VAC
- **Motor:** Reversing, brushless DC motor
- **Gear Train:** Permanently lubricated steel gears
- **Corrosion Resistant Enclosure:** NEMA 4X PC/PET enclosure with stainless steel trim
- **Electrical Connection:** NEMA 4X cable gland with two-meter cable
- **Visual Position Indication:** Flat disc position indicator
- **LED Position Indication:** RED closed, GREEN open, BLUE fault
- **Manual Override:** Manually cycle valve via electroless nickel-plated hex key
- **Selectable Control Signal:** User can select 4-20 mA, 0-20 mA, 0-10 VDC, or 1-5 VDC
- **Reverse Acting:** User can select standard operation or reverse acting
- **Selectable Fail Position:** If control signal is lost, the unit can be calibrated to fail as is, fail open, or fail close
- **Transmitter:** Current or voltage transmitter (matching the control signal) is standard equipment
- **Alarm Contact:** Dry contact rated 0.1 Amp @ 250 VAC, 0.5 Amp @ 30 VDC for alarm status (over torque, as an example)
- **QR Code:** Links to user manual; includes wiring schematic
- **Space Heater:** Internally wired to limit condensation
- **CE Compliant:** All actuators are CE labeled and compliant
- **75% Duty Cycle:** Extended duty cycle is ideal for high cycling applications
- **Simple Wiring:** Wiring technique is the same for all voltage units
- **Local Controls:** Used with OLED and push buttons, a user can locally open or close units via password

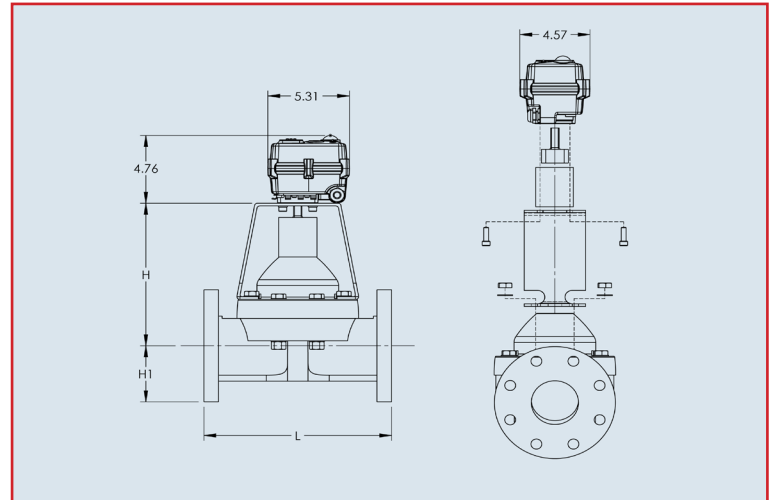

## Dimensions (inch)

Size	1/2"	3/4"	1"	1-1/4"	1-1/2"	2"	2-1/2"	3"	4"
H	3.65	3.73	3.97	4.11	6.28	6.90	9.52	10.25	11.00
H1	1.75	1.94	2.12	2.31	2.50	3.00	3.50	3.75	4.50
L	4.25	5.88	5.88	6.38	6.94	7.94	9.84	10.38	12.94
MODEL	S50MT	S50MT	S50MT	S50MT	S50MT	S50MT	S50MT	S50MT	S50MT

See catalog for L dimension of true union valves

## Engineering Data

Size	Model	Torque (in/lbs)	95-265 VAC		Cycle time (seconds)*	Weight (lbs)
			Amp Draw	Duty Cycle		
1/2"	S50MTHC1C3W	442	.24	75%	52	5.1
3/4"	S50MTHC1C3W	442	.24	75%	52	5.4
1"	S50MTHC1C3W	442	.24	75%	52	5.9
1-1/4"	S50MTHC1C3W	442	.24	75%	52	6.6
1-1/2"	S50MTHC1C3W	442	.24	75%	68	9.8
2"	S50MTHC1C3W	442	.24	75%	84	11.6
2-1/2"	S50MTHC1C3W	442	.24	75%	100	17.9
3"	S50MTHC1C3W	442	.24	75%	100	20.2
4"	S50MTHC1C3W	442	.24	75%	100	29.4

Amp draw is considered locked rotor

\*Cycle times are approximate

Duty cycle shown for ambient temp (73° F)

# TYPE-14 DIAPHRAGM VALVE WITH SERIES 19 **SMART** MODULATING ELECTRIC ACTUATOR (95-265 VAC)

## Wiring Diagram

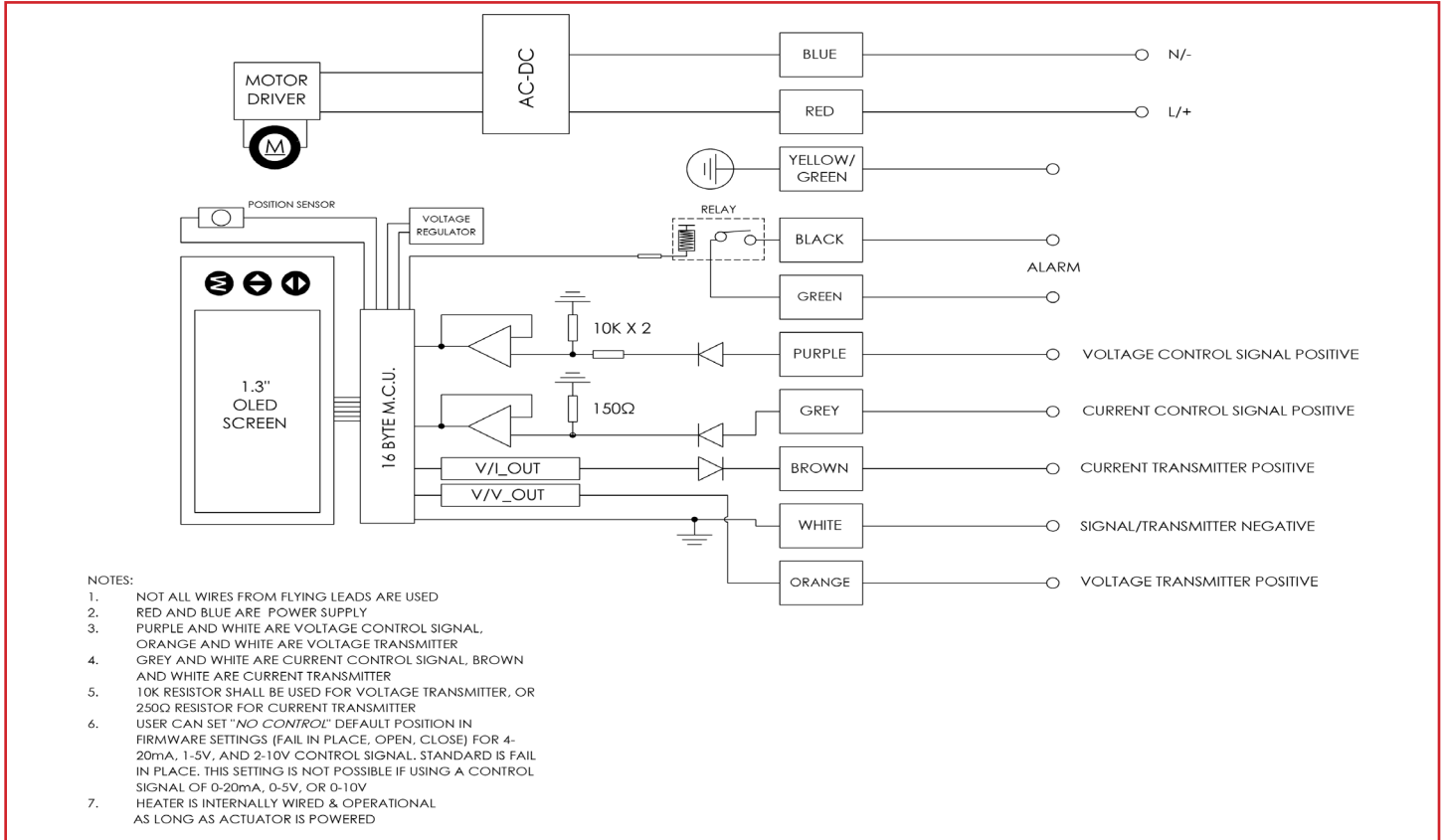

## Sample Specifications

All Series 19 SAV smart modulating multiturn electric actuators shall have a brushless DC motor that accepts multiple voltages, permanently lubricated steel gears, NEMA 4X PC/PET enclosure with stainless steel trim, visual position indication, ISO 5211 valve mounting platform, manual override, and be CE compliant. Standard features shall include a heater; transmitter; field selection of various control signals, field selection of fail position (upon loss of control signal), one set of dry contacts for alarm reporting, LED indicator for position and alarm conditions, an OLED screen with push buttons, local controls, and a QR code that links to its user manual and wiring schematic.

