

Polygon™, Polygon™ LT Fusion Machines

Models: A729801, A729802, A729803, A729804, A729805, A04P0978372



Asahi/America, Inc.

ProWeld® Equipment

800-343-3618



Powered by



Operator's Manual



Manual: 729601
Revision A 04/23
Original Language: English

**Copyright 2023, 2019
McElroy Manufacturing, Inc.
All rights reserved.
P.O. Box 580550
Tulsa, Oklahoma 74158-0550, USA**

Important Safety Information

Most accidents that involve product operation, maintenance and repair are caused by failure to observe basic safety rules or precautions. An accident can often be avoided by recognizing potentially hazardous situations before an accident occurs. A person must be alert to potential hazards. This person should also have necessary training, skills and tools to perform these functions properly.

Advanced training is offered through McElroy University. Course offerings are meant to enhance your efficiency, productivity and safety in the proper use of McElroy equipment.

Improper operation, maintenance or repair of this product can be dangerous and could result in injury or death.

Do not operate this product until you have carefully read, and understand all the sections of this manual, and all other equipment manuals that will be used with it.

Follow all applicable federal, state, local, and industry specific regulations.

The hazards are identified by the "Safety Alert Symbol" and followed by a "Signal Word" such as "DANGER", "WARNING" or "CAUTION". The Safety Alerts are shown below.

The meaning of these safety alert symbols are as follows:

 **DANGER** - Indicates an imminently hazardous situation which, if not avoided, will result in death or serious injury.

 **WARNING** - Indicates a potentially hazardous situation which, if not avoided, could result in death or serious injury.

 **CAUTION** - Indicates a hazardous situation which, if not avoided, may result in minor or moderate injury.

Signal words "NOTICE" and "IMPORTANT" are used to bring attention to important information.

The meaning of these signal words are as follows:

"NOTICE" - Can keep you from doing something that might damage the machine or someone's property. It may also be used to alert against unsafe practices.

"IMPORTANT" - Can help you do a better job or make your job easier in some way.

McElroy cannot anticipate every possible circumstance that might involve a potential hazard. The warnings in this publication and on the product are, therefore, not all inclusive. If a tool, procedure, work method or operating technique that is not specifically recommended by McElroy is used, you must satisfy yourself that it is safe for you and for others. You should also ensure that the product will not be damaged or be made unsafe by the operation, maintenance or repair procedures that you choose.

The information, specifications, and illustrations in the publication are on the basis of information that was available at the time that the publication was written. The specifications, pressures, measurements, adjustments, illustrations, and other items can change at any time. These changes can affect the service that is given to the product. Obtain the complete and most current information before you start any job. The most current information is available at our website

www.mcelroy.com.

TX05337-04-18

 WARNING	Cancer and Reproductive Harm - www.P65warnings.ca.gov	81633861
--	---	----------

 **WARNING**

When replacement parts are required for this product McElroy recommends using McElroy replacement parts or parts with equivalent specifications including, but not limited to, physical dimensions, type, strength and material.

Failure to heed this warning can lead to premature failures, product damage, personal injury or death.

TABLE OF CONTENTS

FOREWORD

Literature Information	1 - 1
Safety	1 - 1
Operation.....	1 - 1
Maintenance.....	1 - 1
Patent Information	1 - 2
Replacement Literature	1 - 2
Nameplate Location	1 - 2
Replacement Parts	1 - 2
Limited Warranty	1 - 3

SAFETY

General Safety	2 - 1
Safety Equipment.....	2 - 1
Heater Is Not Explosion Proof.....	2 - 2
Electric Motors are Not Explosion Proof.....	2 - 2
Electrical Safety.....	2 - 2
Power Tool Safety	2 - 2
Facer Blades Are Sharp	2 - 2
Heater is Hot	2 - 3
Sound Information.....	2 - 3
Fusion Procedures.....	2 - 3
Do Not Modify Machine.....	2 - 3

GENERAL INFORMATION

Theory of Butt Fusion	3 - 1
Nomenclature	3 - 1
Mitered Fusion Angles.....	3 - 3
Socket Fusion Jaws	3 - 4
Change Polygon™ Jaws	3 - 5
Remove Outer Jaws	3 - 6
Configure Machine for High or Low Force.....	3 - 7
Polygon LT Nomenclature.....	3 - 8
Change/Remove Jaws (Polygon LT).....	3 - 9
Polygon LT Inserts.....	3 - 10
Polygon LT 100 PSI Auxillary Gauge.....	3 - 11
DataLogger® Graphs	3 - 12

OPERATION - BUTT FUSION

Load Pipe	4 - 1
Prepare Heater	4 - 2
Prepare Facer	4 - 2
Face Pipe.....	4 - 3
Calculate Fusion Pressure.....	4 - 4
Check Alignment.....	4 - 4
Insert Heater	4 - 4

Heating the Pipe	4 - 5
Fusing the Pipe.....	4 - 5
Remove Fused Pipe	4 - 6

OPERATION - MITERED FUSION (POLYGON)

Load Pipe	5 - 1
Prepare Heater.....	5 - 2
Prepare Facer.....	5 - 2
Face Pipe.....	5 - 3
Calculate Fusion Pressure.....	5 - 4
Check Alignment.....	5 - 4
Insert Heater	5 - 4
Heating the Pipe	5 - 5
Fusing the Pipe.....	5 - 5
Remove Fused Pipe	5 - 5

STORAGE/TRANSPORT

Storage/Transport Polygon.....	6 - 1
Storage/Transport Polygon LT	6 - 3

MAINTENANCE

Preventative Maintenance	7 - 1
Clean Machine.....	7 - 1
Check Machine Operation	7 - 1
Fasteners Are Tight	7 - 1
Changing Heater Plates/Adapters	7 - 1
Facer Blades	7 - 2
Change/Fill Hydraulic Fluid.....	7 - 2
Change/Fill Gear Oil.....	7 - 3

SPECIFICATIONS

Polygon Specifications.....	8 - 1
Polygon LT Specifications.....	8 - 2

NOTES

Notes	9 - 1
-------------	-------

FOREWORD

Literature Information

This manual should be stored in a protected location for future reference. Use the literature holder if provided with the product. Digital copy will contain hyperlinks. Press Alt + Left Arrow to return to the selected hyperlink.

This manual contains safety information, operation instructions, transportation information, lubrication information and maintenance information.

Some photographs or illustrations in this publication show details or equipment that can be different from your machine. Guards and covers might have been removed for illustrative purposes.

Continuing improvement and advancement of product design might have caused changes to your machine which are not included in this publication. Read, study and keep this manual with the machine.

Whenever a question arises regarding your machine, or this publication, please contact McElroy Technical Services at 918-831-9224 or techsupport@mcelroy.com

Safety

The safety section lists basic safety precautions. In addition, this section identifies the text and locations of warning signs and labels used on the machine.

Read and understand the basic precautions listed in the safety section before operating or performing maintenance and repair on this machine.

Operation

The operation section is a reference for the new operator and a refresher for the experienced operator. This section includes a discussion of gauges, switches, machine controls, accessories and transportation.

Photographs and illustrations guide the operator through correct procedures of setting up, checking and operating the machine.

Operating techniques outlined in this publication are basic. Proficiency develops as the operator gains knowledge and experience with the machine and its capabilities.

Maintenance

The maintenance section is a guide to equipment care. The maintenance schedule lists the items to be maintained at a specific service interval. Items without specific intervals are listed under the "As Needed" service interval. The schedule lists the page for the step-by-step instructions required to accomplish the scheduled maintenance. Use the schedule as an index for all maintenance procedures.

Some maintenance procedures may be referenced in a manual pertaining to that component of the machine. For example, maintenance for an engine component would have its intervals and procedures in the engine operator's manual.

Use the hour meter (if equipped) to determine servicing intervals. Calendar intervals will be used instead of hour meter intervals if no hour meter is equipped on a machine. Recommended service should always be performed at the interval that occurs first.

Under extremely severe, dusty or wet operating conditions, more frequent lubrication than is specified in the maintenance schedule might be necessary.

Asahi/America Training Standards

Since 1984, Asahi/America, Inc. has been teaching contractors the benefits of welding thermoplastic piping systems in industrial and high purity applications. Our partnership with McElroy allows us to leverage their state-of-the-art Learning Management System (LMS) using Asahi/America technical standards across all Asahi piping systems.

For more than 30 years, McElroy has been the only pipe fusion machine manufacturer to continuously offer advanced training. Course offerings are meant to enhance your efficiency, productivity and safety in the proper use of McElroy machines. Asahi/America learning portal classes powered by McElroy University are structured so that the skills learned and the machines used in each class closely match the machines found on pipelining jobsites.

Training modules specific to Asahi/America piping systems available for purchase online and required to be completed prior to onsite training by Asahi/America personnel.

This manual is intended as a guide only and does not take the place of proper training by qualified instructors. The information in this manual is not all inclusive and cannot encompass all possible situations that can be encountered during various operations.

Patent Information

This product and other products could be protected by patents or have patents pending. All the latest patent information is available at patent.mcelroy.com

Replacement Literature

This product is shipped with a printed operator's manual. If the manual becomes lost or damaged, order a replacement manual or download and print a copy of the manual at https://www.asahi-america.com/images/x-assets/PDF/Miniplast_Polygon_LT_Manual.pdf.

Nameplate Location

Every machine has a name plate that includes the machine's model number, serial number, and power requirements. The model and serial numbers can be used to register the machine online and activate the warranty. Reference warranty card for information on registering your product. Asahi/America's rental tools also have the rental serial number on tool and shipping crate, as well. This serial number required when calling Asahi/America with questions for rental tools.

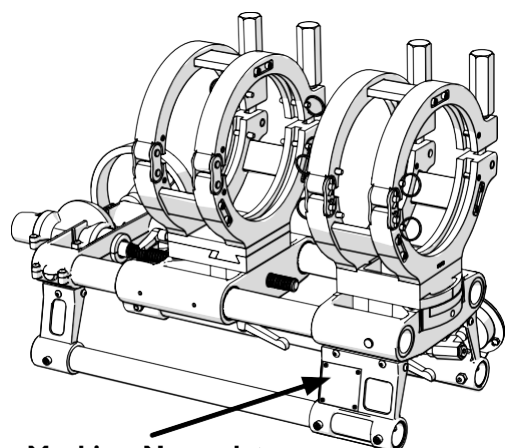

Machine Nameplate

CD02338-11-19-18

Replacement Parts

Contact Asahi/America for replacement parts on Asahi-supplied tools

Refer to the McElroy parts finder at www.mcelroy.com to locate parts for purchase. Reference the model number on the nameplate of the machine when using the parts finder.

Note: This manual covers both the Polygon LT™ and the Polygon™. Please make sure to follow the proper section for your tool in use.

TX05338-04-18

Asahi/America Rental Warranty

Asahi/America's comprehensive rental equipment policies can be found on our website here: <https://www.asahi-america.com/support/rental-equipment-policy>

All rental equipment is warranted for six (6) months of on-site usage. All tool failures within this six-month period are handled as indicated in Section V. After six months usage it is recommended that the equipment be returned for regular maintenance and warrantee renewal. Equipment held longer than six months without return is held at the renter's risk.

Used Equipment Warranty

Purchase of refurbished/used equipment carries a 90-day warranty.

New Equipment Warranty

Purchase of new Asahi/America versions of McElroy equipment carries a 5-year limited warranty. Details can be found here: <https://www.mcelroy.com/warranty.htm>

Asahi/America Tool Department Contacts

For technical or tool related questions, please contact:

Rental Equipment Manager – 781-388-4618 or toolmanager@asahi-america.com

For Rental Administration, Billing, and Returns – 781-388-4623 or toolrental@asahi-america.com

Welding and Standards Manager – 781-388-4577

To schedule field service or training, please enter information here: <https://www.asahi-america.com/support/field-technician-request>

For technical service related questions, please contact:

High Purity, Double Wall, or Industrial Piping – 781-321-5409 or pipe@asahi-america.com

Asahi/America Corporate Headquarters – 800-343-3618 or asahi@asahi-america.com

Asahi/America, Inc.

655 Andover St.

Lawrence, MA 01843

SAFETY

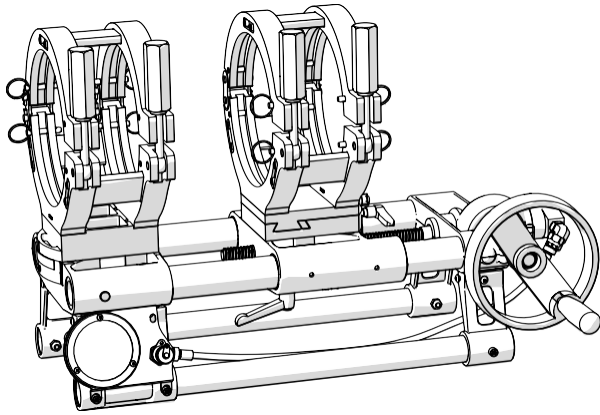

CD02339-12-17-18

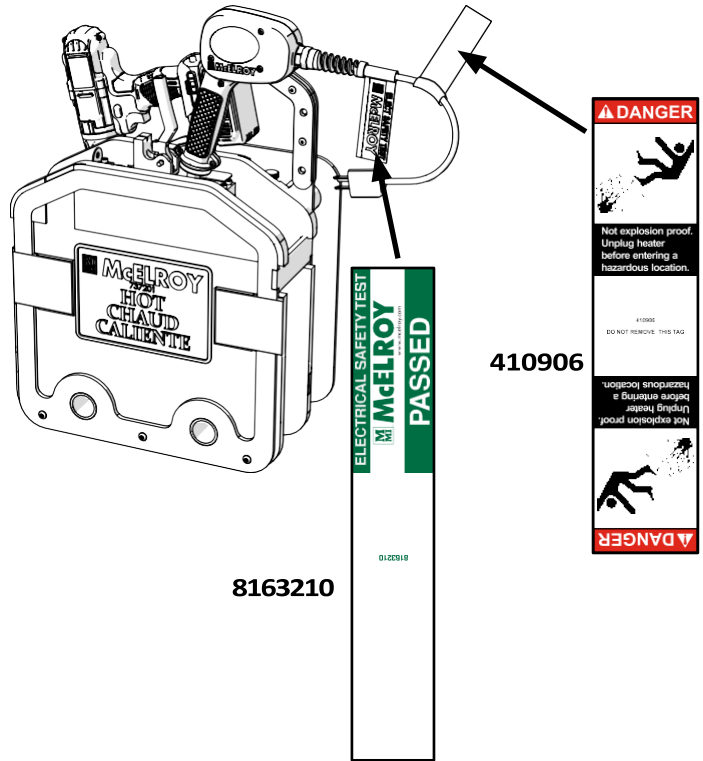

8163210

410906

Safety

There can be several specific safety messages on this machine. The exact location of the hazards and the description of the hazards are reviewed in this section. Please become familiarized with all safety messages.

Make sure that all of the safety messages on the machine are legible. Clean the safety messages or replace the safety messages if you cannot read the words. Replace if the illustrations are not legible. When you clean the safety messages, use a cloth, water and soap. Do not use solvent, gasoline, or other harsh chemicals to clean the safety messages. Solvents, gasoline, or harsh chemicals could loosen the adhesive that secures the safety message or damage the print of the safety message.

Replace any safety message that are damaged, or missing. If a safety message is attached to a part that is replaced, install a safety message on the replacement part. New safety messages can be ordered from McElroy using the part number listed.

General Safety

Safety is important. Report anything unusual that you notice during set up or operation.

LISTEN for thumps, bumps, rattles, squeals, air leaks, or unusual sounds.

SMELL odors like burning insulation, hot metal, burning rubber, hot oil, or natural gas.

FEEL any changes in the way the equipment operates.

SEE problems with wiring and cables, hydraulic connections, or other equipment.

REPORT anything you see, feel, smell, or hear that is different from what you expect, or that you think may be unsafe.



SAFE1ST-2-21-18

Safety Equipment

Wear a hard hat, safety shoes, safety glasses, and other applicable personal protective equipment.

Remove jewelry and rings, and do not wear loose fitting clothing or long hair that could catch on controls or moving machinery. Remove any loose safety equipment during an operation that could be drawn into or caught in the machine.

Ensure proper fire prevention or other fire-fighting equipment is available and all personnel know how and when to use it.

Heater is Hot

This safety message is located on the cord of the heater.

⚠ DANGER

This heater is not explosion proof. Operation of heater in an explosive atmosphere without necessary safety precautions will result in serious injury or death.

When operating in an explosive atmosphere, the heater should be brought up to temperature in a safe environment, then unplugged before entering the explosive atmosphere for fusion.



WR00080-2-21-18

Electric Motors are Not Explosion Proof

⚠ DANGER

Electric motors are not explosion proof. Operation of these components in an explosive atmosphere without necessary safety precautions will result in serious injury or death.

The Polygon™ facer drill motor cannot be used manually and must not be used in an explosive atmosphere.



WR00080-2-21-18

WR00080-4-12-93

⚠ WARNING

Always ensure equipment is properly grounded. It is important to remember that if you are working in a wet environment with electrical devices. Proper ground connections help to minimize the chances of an electric shock.

Frequently inspect electrical cords and unit for damage. Have damaged components replaced and service performed by a qualified electrician.

Do not carry electrical devices by the cord

NOTICE: Always connect units to the proper power source as listed on the unit, or in the owner's manual. Use GFCI electrical connections when available.



WR00065-2-21-18

Power Tool Safety

⚠ WARNING

Read and understand the all instructions provided with your power tool. Failure to follow all the power tool instructions, may result in electric shock, fire and/or serious personal injury.

Facer Blades Are Sharp

⚠ WARNING

Facer blades are sharp and can cut. Never attempt to remove shavings while the facer is running, or is in the facing position between the jaws. Use care when operating the facer, and when handling the unit.

NOTICE: Remove the battery from the drill motor before attempting any maintenance or adjustment of facer blades.

NOTICE: Never extend the facer blades beyond the inner or outer circumference of the facer.

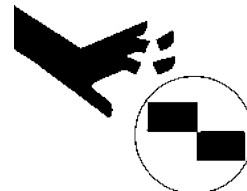

WR00073-2-21-18

Heater is Hot

⚠ CAUTION

The heater is hot and will burn clothing and skin. Keep the heater in its insulated heater stand or blanket when not in use, and use care when heating the pipe.

NOTICE: Use only a clean dry lint free non-synthetic cloth to clean the heater plates.



WR00030-2-21-18

Sound Information

The operator Equivalent Sound Pressure Level is 86 dB(A). This is measured from the operator location at the machine. The distance of the measurement is 24" (61 cm) from the machine.

Hearing protection may be needed when the machine is operated during facing or in a noisy environment.

Fusion Procedures

Obtain a copy of the pipe manufacturer's fusion procedures or appropriate joining standard for the pipe being fused. Follow the procedure carefully, and adhere to all specified parameters.

NOTICE: Failure to follow the pipe manufacturer's fusion procedures or appropriate joining standard could result in a bad fusion joint.

Do Not Modify Machine

Make no modifications to your equipment unless specifically recommended or requested by McElroy.

TX05340-04-18

GENERAL INFORMATION

Theory of Butt Fusion

The principle of heat fusion is to heat two pipe surfaces to a designated temperature, and then fuse them together by application of force. This develops pressure which causes flow of the melted materials, which causes mixing and thus fusion. When the thermoplastic material is heated, the molecular structure is transformed into an amorphous condition. When fusion pressure is applied, the molecules from each thermoplastic part mix. As the joint cools, the molecules return to their form, the original interfaces are gone, and the fitting and pipe have become one monolithic unit. A strong, fully leak tight connection is the result.

The principal operations include:

- Clamping** The pipe pieces are held axially and radially to allow all subsequent operations to take place.
- Facing** The pipe ends are faced to establish clean, parallel mating surfaces perpendicular to the centerline of the pipes.
- Aligning** The pipe ends are aligned with each other to minimize mismatch of the pipe walls.
- Heating** A melt pattern that penetrates into the pipe is formed around both pipe ends.
- Fusing** The melt patterns are joined with a specified force, which is constant around the pipe interfacial area.
- Cooling** The fusion joint is held immobile with a specified force until adequately cooled.
- Inspecting** Visually examine the entire circumference of the joint for compliance with the standard or fusion procedure used.



Nomenclature

Polygon™ Carriage

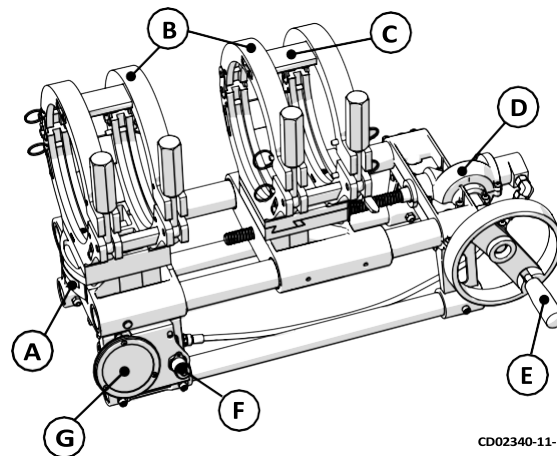

CD02340-11-19-18

A - Angle Scale Label

Used to set the angle of the jaws for mitered fusions.

B - 180mm Pipe Jaws

Clamps and holds the pipe. The jaws can rotate for mitered pipe fusions. The movable jaws can also be shifted laterally for alignment. Jaws can be removed from the sets to create a two or three jaw machine. The jaws can be removed and socket fusion jaws can be installed.

C - Spacer Plates

Connects the set of jaws and can be removed so that a jaw can be removed from the jaw assembly.

D - Gearbox

Translates the rotation of the handwheel to open and close the carriage.

E - Handwheel

Rotates to open and close the carriage. The handle can be folded in for storage.

F - DataLogger® Port

Connect a DataLogger® to the Polygon™.

G - Pressure Gauge

Displays the pressure created when closing the carriage.

Heater

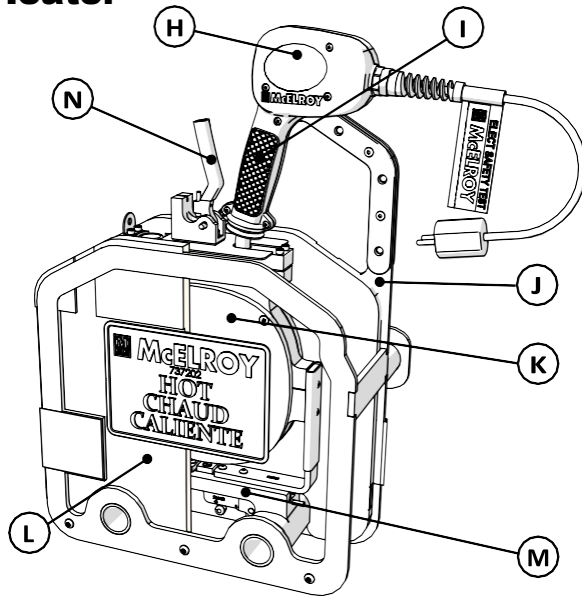

CD02385-12-17-18

H - Heater Information Label

Provides model number, power and indicator light information.

I - Heater Handle

Location to hold the heater and has a potentiometer to adjust the heater temperature.

J - Heater/Facer Stand

Stand to store the heater and facer when not being used. Has a handle so it can be carried.

K - Heater Butt Plate

Non-stick coated plates that attach to the heater body.

L - Insulated Heater Bag

This bag is attached to the stand and insulates the heater while stored in the stand. Helps maintain the set heater temperature.

M - Heater Guide Rod Bracket Assembly

The base is used to attach the heater to the guide rods of the Polygon™ and the heater/facer stand. It locks to the Polygon™ or heater/facer stand. The base has detents so the heater may be shifted laterally to align for mitered fusions.

N - Heater Guide Rod Bracket Assembly Lock Release

Actuate the lever to release the lock so the heater can be removed.

Facer

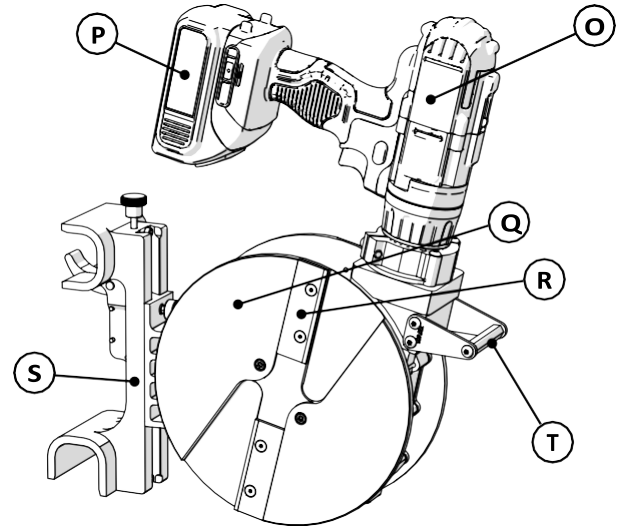

CD02387-12-17-18

O - Drill

Drives the facer, turning the blade holders. It has three speeds and is actuated by the trigger on the handle.

P - Drill Rechargeable Battery

Rechargeable battery that is charged by removing the battery and placing it on the charging dock.

Q - Blade Holder

Driven by the drill motor and holds the facer blades.

R - Facer Blades

Cutting blades that are attached to the blade holders and shave the ends of the pipe while being rotated.

S - Facer Guide Rod Bracket Assembly

The base is used to attach the facer to the guide rods of the Polygon™ and the heater/facer stand. It has a locking pin to lock the base to the Polygon™ or stand. The base has detents so the facer may be shifted laterally to align for mitered fusions.

T - Auxiliary Handle

Provides a handle for easy removal of the facer from the carriage.

Mitered Fusion Angles

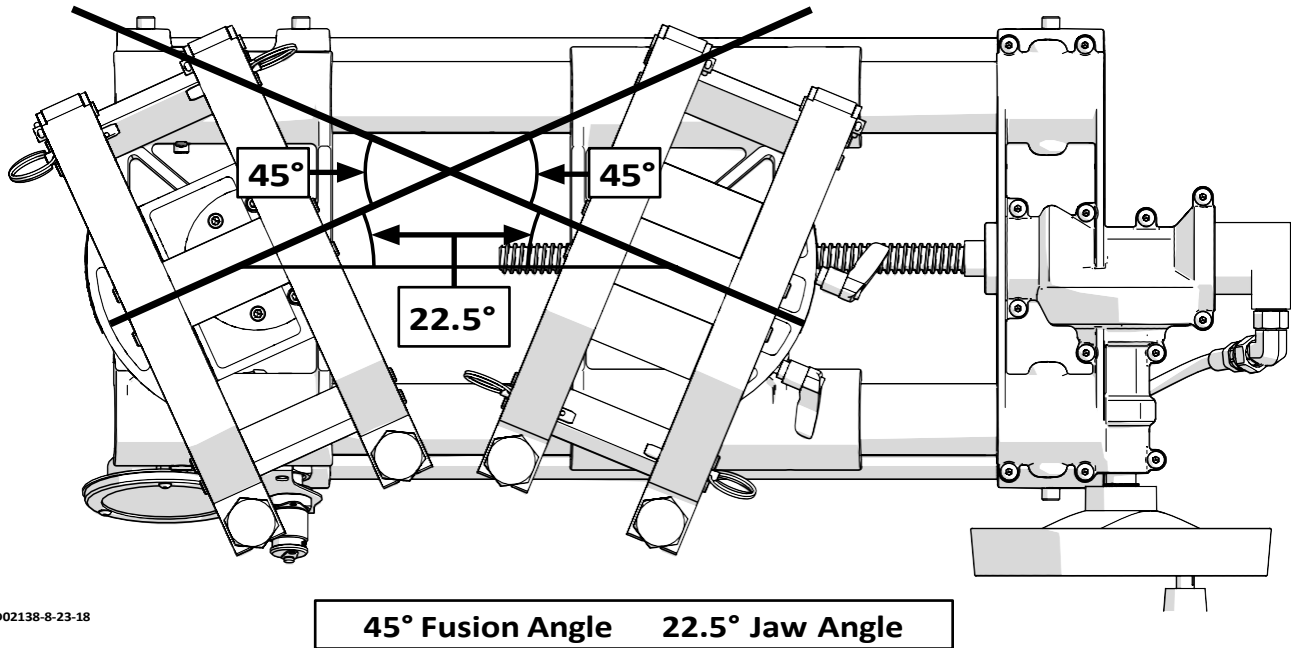

CD02138-8-23-18

The mitered fusion angle is set by loosening the jaws rotation and rotating the jaws to the desired angle using the angle scale gauge.

To Loosen the Jaw:

Loosen the clamp underneath the jaws.

IMPORTANT: There may be resistance in the clamp while loosening the jaws. Continue to turn the clamp past the resistance to completely loosen the jaw.

Once the jaws are free to rotate, align the mark on the base of the jaws to the desired jaw angle.

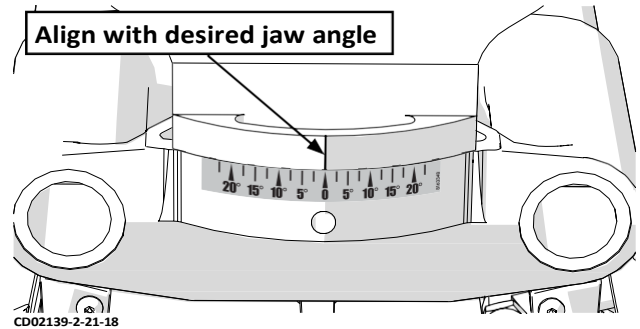

Desired Fusion Angle	Jaw Angle
45°	22.5°
40°	20°
35°	17.5°
30°	15°
25°	12.5°
20°	10°
15°	7.5°
10°	5°
5°	2.5°

Socket Fusion Jaws

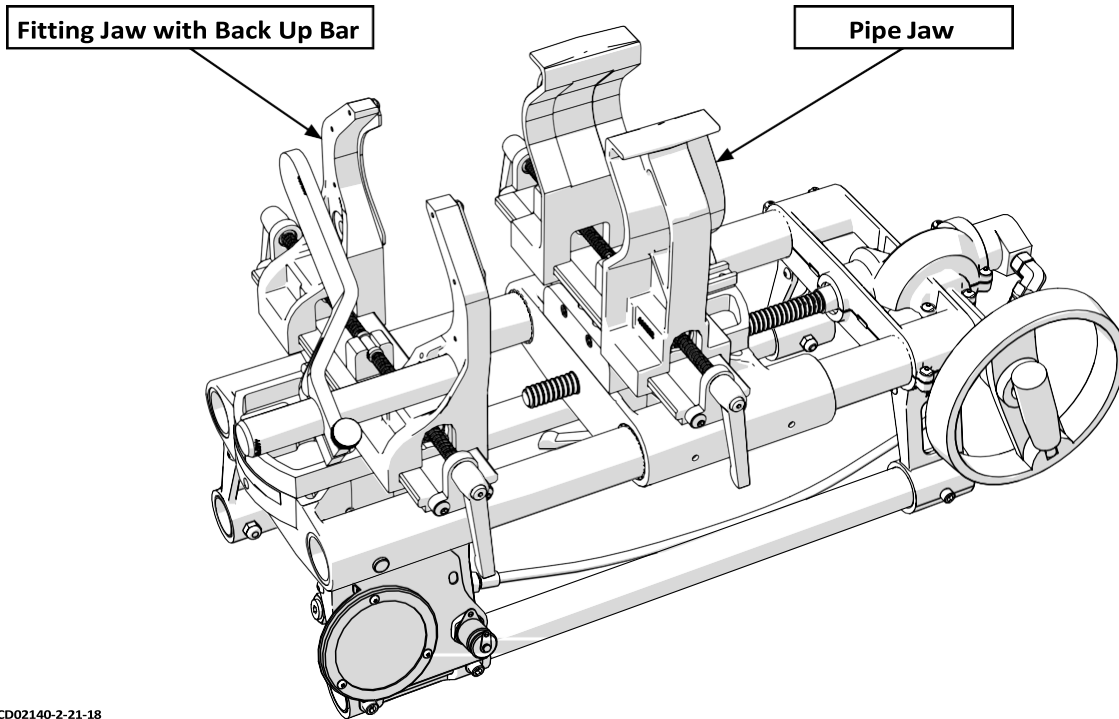

CD02140-2-21-18

Socket fusion jaws can be installed to make pipe and fitting fusions using the Polygon™. The fitting is clamped in the Fitting Jaw and the Back Up Bar applies resistance to the fitting to prevent the fitting from moving in the jaw. The pipe is clamped in the movable Pipe Jaw.

Refer to section [“Operation - Socket Fusion”](#) for instructions on how to perform a socket fusion using the Polygon™ equipped with the socket fusion jaws.

Change Polygon™ Jaws

Remove Fixed Jaw:

- 1) Loosen the clamp under the fixed jaw until the clamp is removed from the jaw.

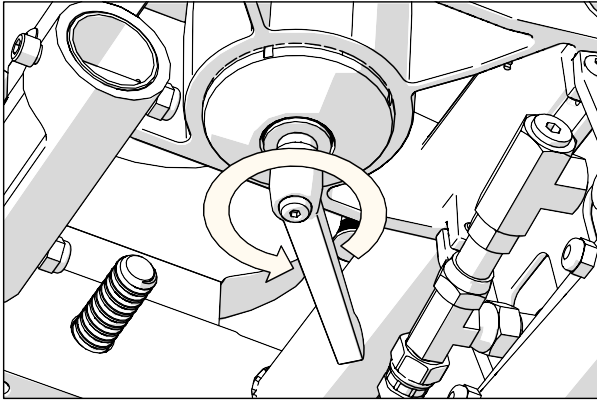

CD02142-2-21-18

- 2) Remove the jaw pipe support. Rotate fixed jaw approximately 45° clockwise to the end of rotation.

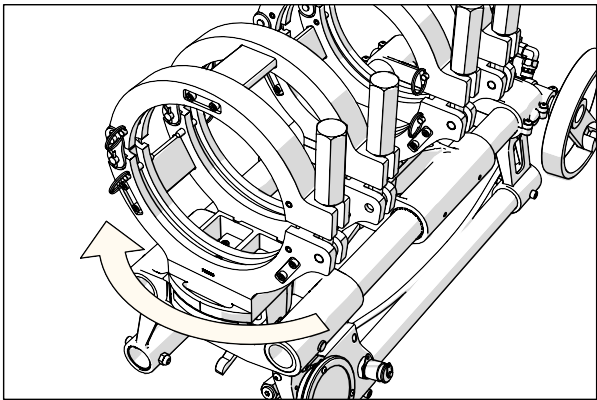

CD02343-11-19-18

- 3) Lift the fixed jaw up and away from the Polygon™ base.

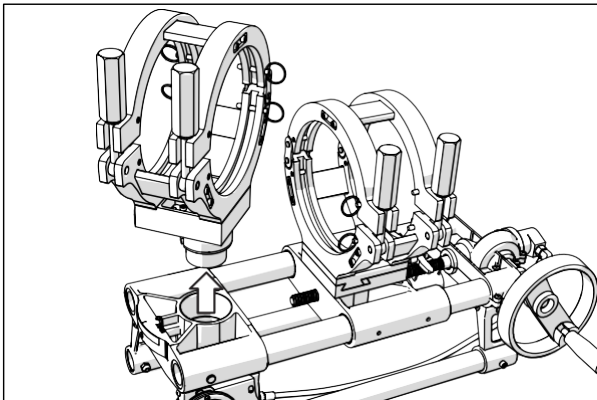

CD02344-11-19-18

Remove Movable Jaw:

- 1) Loosen the clamp under the movable jaw until the clamp is removed from the jaw.

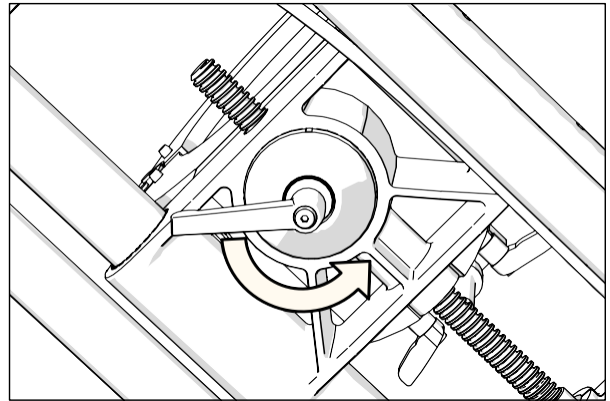

CD02145-2-21-18

- 2) Close the carriage completely.

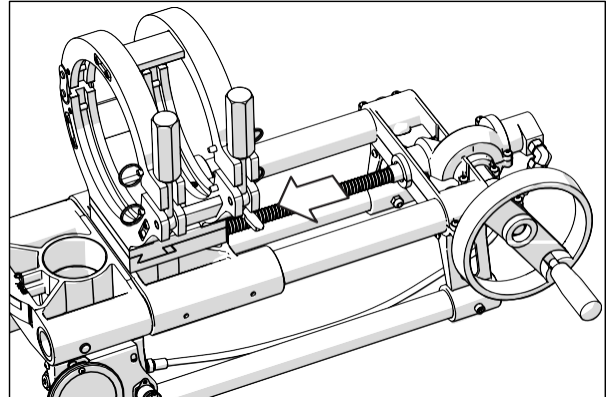

CD02345-11-19-18

- 3) Lift the movable jaw up and away from the Polygon™ base.

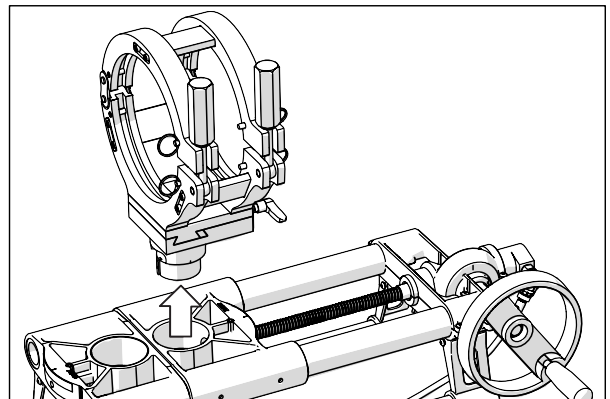

CD02346-11-19-18

- 4) Install the other set of jaws in reverse order. Install the movable jaw first and then open the carriage so that the fixed jaw can be installed. Tighten both clamps after installation to secure the jaws in the Polygon™ base.

Remove Outer Jaws

The Polygon™ can be configured into a 2 or 3 jaw fusion machine. Outer jaws can be removed from both sets of jaws.

Remove Outer Jaw:

- 1) Remove the 6 screws that attach the inner jaw to the outer jaw.

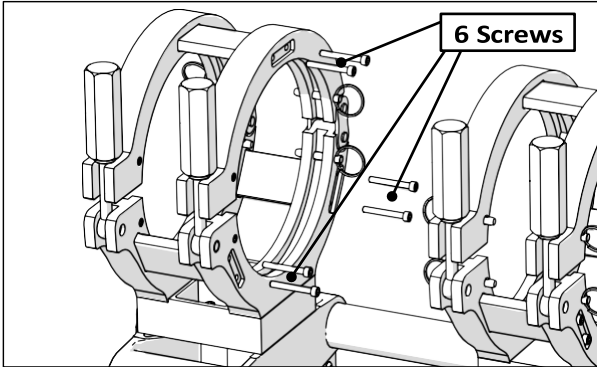

CD02350-11-26-18

- 2) Remove the screw attaching the jaw to the jaw base.

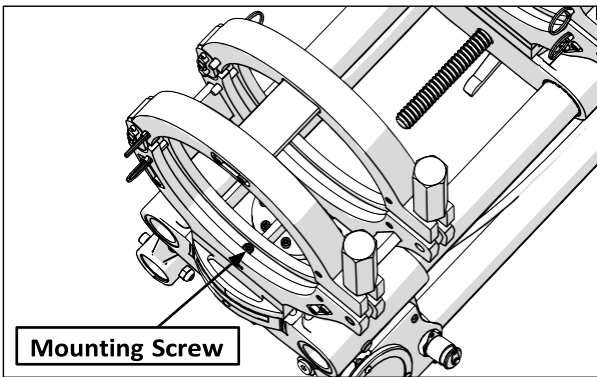

CD02351-11-26-18

- 3) Remove the outer jaw from the base. The outer jaw on the movable set is removed using the same steps.

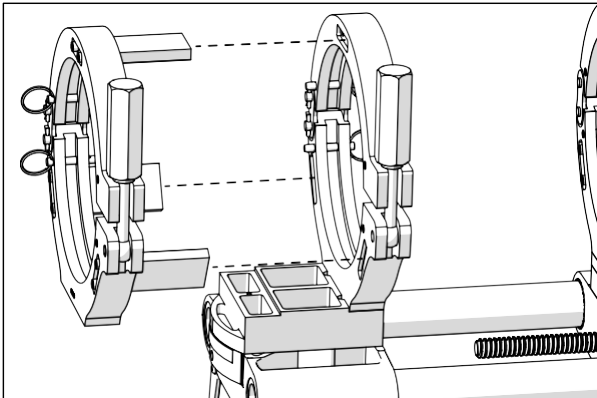

CD02352-11-26-18

Configure Machine for High or Low Force

The Polygon™ package comes equipped with either a 400 psi or 2000 psi pressure gauge. When calculated fusion pressures exceed 400 psi, a high pressure gauge and larger handwheel must be installed.

NOTICE: Do not mix the large handwheel with the low pressure gauge. Damage to the gauge will occur from over pressuring.

Remove Pressure Gauge:

- 1) Remove the fitting from the back of the pressure gauge.

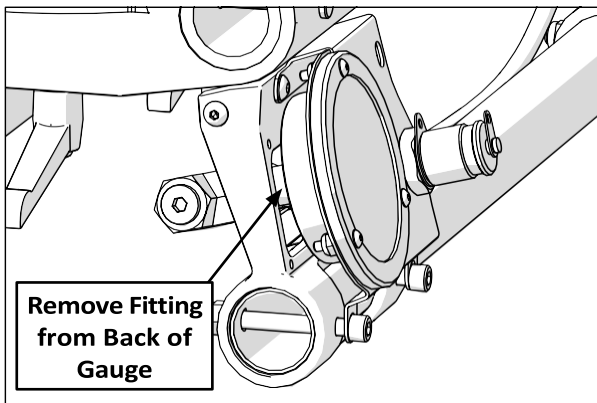

CD02347-11-20-18

- 2) Remove the 3 mounting screws on the gauge bezel and remove the pressure gauge.

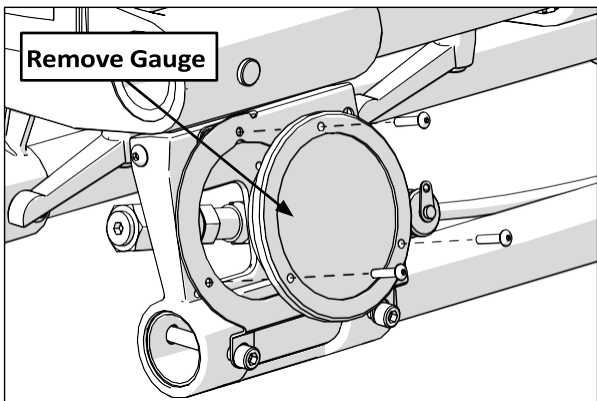

CD02348-11-20-18

Remove Handwheel:

- 1) Remove the snap ring from the shaft of the handwheel.

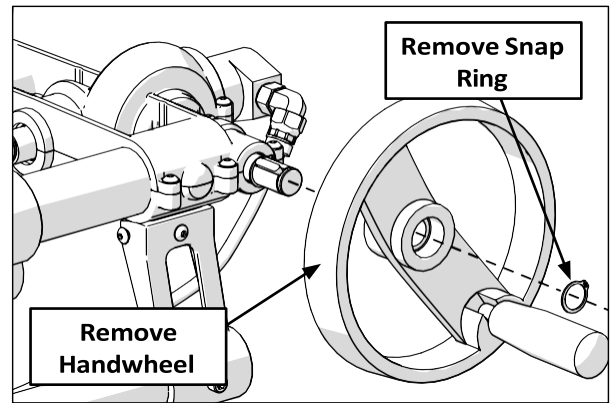

CD02349-11-20-18

- 2) Remove the handwheel from the shaft.

Install Handwheel:

- 1) Move the inner snap ring to the large handwheel snap ring groove.

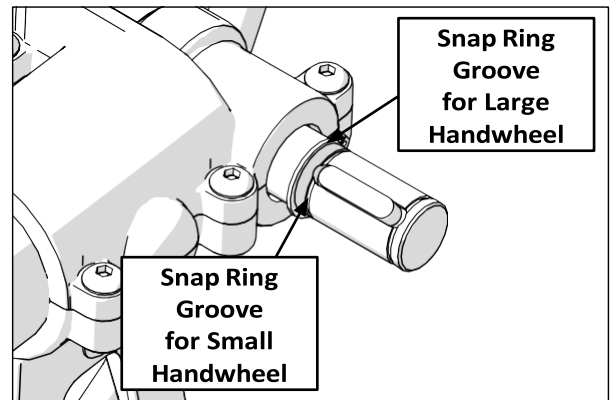

CD02422-1-24-19

- 2) Install the larger handwheel on the shaft ensuring the keyway of the wheel slides over the key on the shaft.
- 3) Replace the snap ring on the shaft.

Install Pressure Gauge:

- 1) Install the high pressure gauge using the 3 mounting screws.
- 2) Attach the hydraulic fitting to the back of the pressure gauge.

NOTICE: Do not mix the large handwheel with the low pressure gauge. Damage to the gauge will occur from over pressuring.

Polygon LT

Nomenclature

Polygon™ LT Carriage

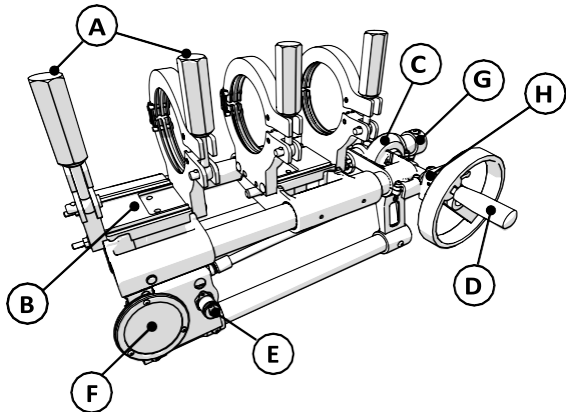

CD02698-03-20-23

A - 110mm Pipe Jaws

Clamps and holds the pipe. Jaws can be removed from the sets to create a two or three jaw machine.

B - Jaw Mount Plates

Plates that the 4 jaws mount to. Can be configured to 2 jaw or 3 jaw configurations.

C - Gearbox

Translates the rotation of the handwheel to open and close the carriage.

D - Handwheel

Rotates to open and close the carriage. The handle can be folded in for storage.

E - DataLogger® Port

Connect a DataLogger® or the 100 PSI Auxillary Gauge to the Polygon™ LT

F - Pressure Gauge

Displays the pressure when closing the carriage.

G - Load Cell Cylinder

Translates the force of closing the carriage to hydraulic pressure that is read on the pressure gauge.

H - Shaft Brake

Locks the position of the carriage, holding pressure applied.

Heater

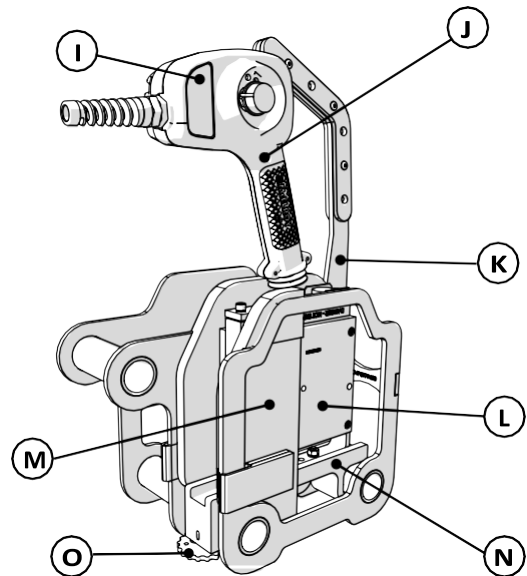

CD02699-03-20-23

I - Heater Information Label

Provides model number, power and indicator light information.

J - Heater Handle

Location to hold the heater and has a potentiometer to adjust the heater temperature.

K - Heater/Facer Stand

Stand to store the heater and facer when not being used. Has a handle so it can be carried.

L - Heater Butt Plate

Non-stick coated plates that attach to the heater body.

M - Insulated Heater Panels

These panels are attached to the stand and insulates the heater while stored in the stand. Helps maintain the set heater temperature.

N - Heater Guide Rod Bracket Assembly

The base is used to attach the heater to the guide rods of the Polygon™ LT and the heater/facer stand. It locks to the heater/facer stand for transport.

O - Heater Guide Rod Bracket Assembly Latch

Rotate the latch to release the lock so the heater can be removed.

Facer

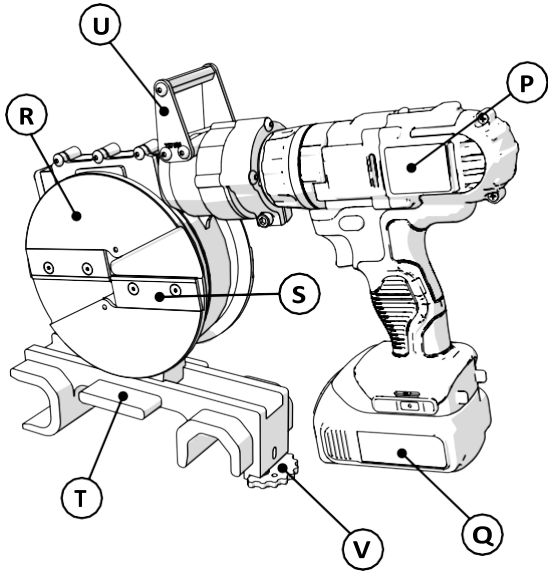

CD02700-03-20-23

P - Drill

Drives the facer, turning the blade holders. It has three speeds and is actuated by the trigger on the handle.

Q - Drill Rechargeable Battery

Rechargeable battery that is charged by removing the battery and placing it on the charging dock.

R - Blade Holder

Driven by the drill motor and holds the facer blades.

S - Facer Blades

Cutting blades that are attached to the blade holders and shave the ends of the pipe while being rotated.

T - Facer Guide Rod Bracket Assembly

The base is used to attach the facer to the guide rods of the Polygon™ LT and the heater/facer stand. It has a locking latch to lock the base to the Polygon™ LT or stand. The base has facer stops built into it.

U - Auxiliary Handle

Provides a handle for easy removal of the facer from the carriage.

V - Facer Guide Rod Bracket Assembly Latch

Rotate the latch to release the lock so the facer can be removed.

Change/Remove Jaws (Polygon LT)

The Polygon™ LT can be configured into a 2 or 3 jaw fusion machine. Outer jaws can be removed from both sets of jaws.

Remove Jaws:

- 1) Remove the two nuts to the carriage bolts on one set of jaws.

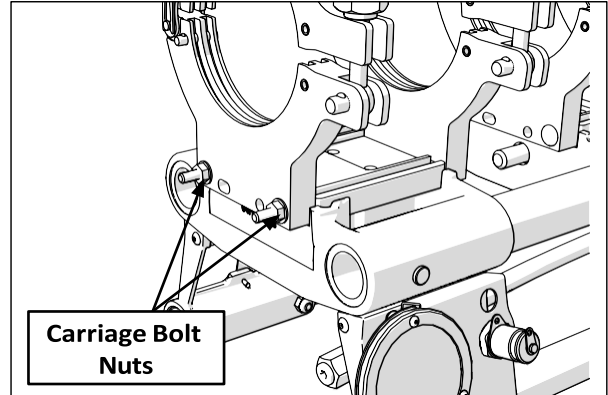

CD02701-03-20-23

- 2) Slide off the outer jaw from the jaw base plate.

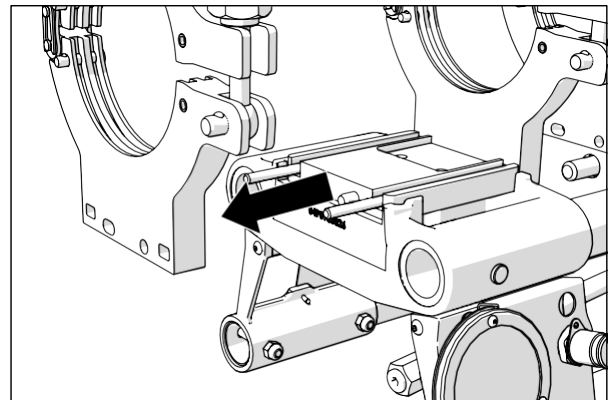

CD02702-03-20-23

- 3) Slide off the inner jaw and carriage bolts from the jaw base plate.

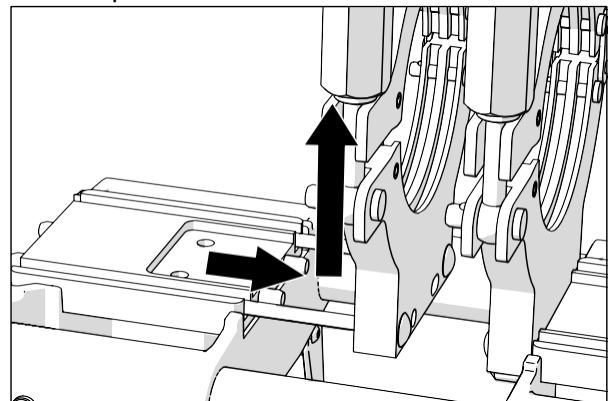

CD02703-03-20-23

- 4) A single jaw from the set can be installed back on the machine or the optional thin jaws can be installed to replace the set.

IMPORTANT: If a single jaw is installed, the nuts will be tightened against the jaw base plate.

Install Jaws:

- 5) Slide the carriage bolts through a jaw of the set and slide the jaw over the pins on the inner jaw side of the jaw base plate.

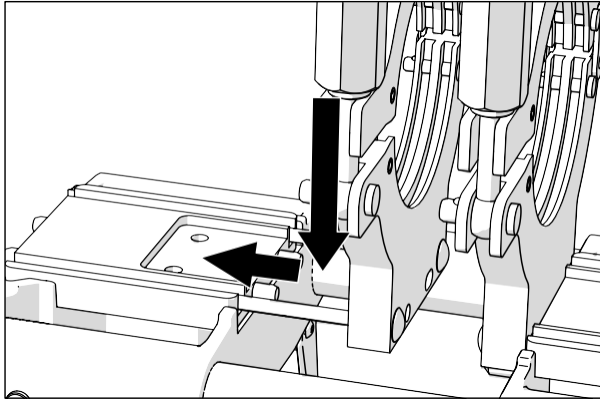

CD02704-03-20-23

- 6) Slide the other jaw over the pins on the outer jaw side of the jaw base plate.

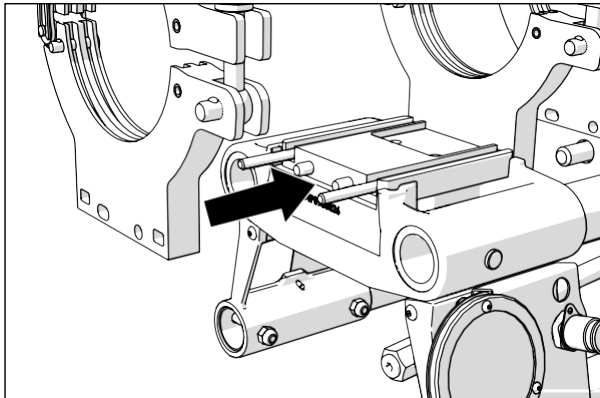

CD02705-03-20-23

- 7) Install the two nuts on the carriage bolts and tighten to secure the jaws to the jaw base plate.

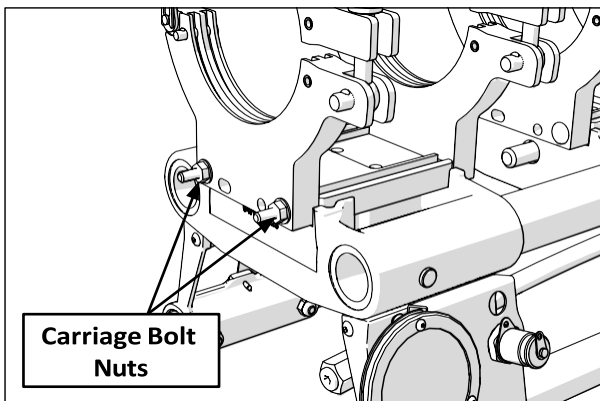

CD02701-03-20-23

Polygon LT Inserts

The Polygon LT jaws can accept up to 2 inserts in the upper jaw and 2 inserts in the lower jaw. Polygon LT inserts are sold separately.

Install Inserts:

- 1) Open the jaws on the machine.

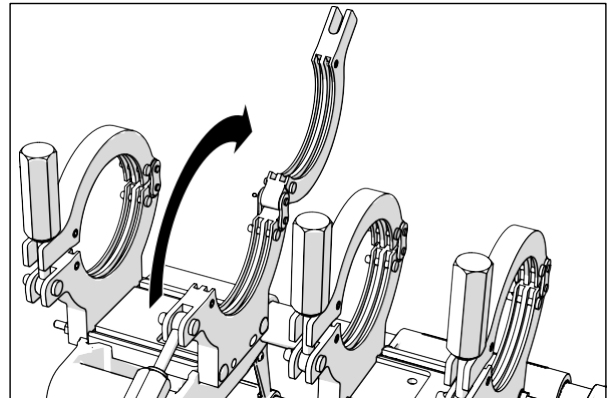

CD02706-03-20-23

- 2) Remove the quick release pins from the upper and lower jaws.

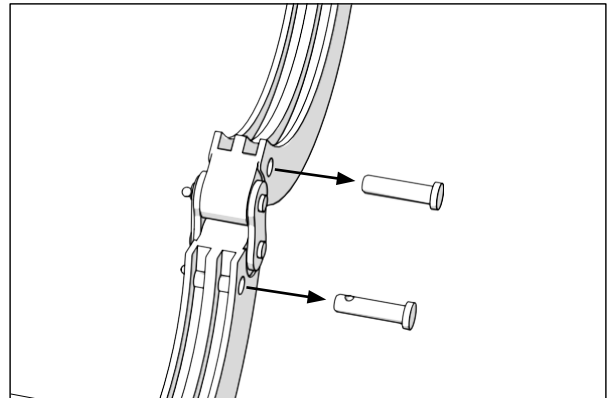

CD02707-03-20-23

- 3) Install the appropriate sized inserts into the lower and upper jaws of the machine.

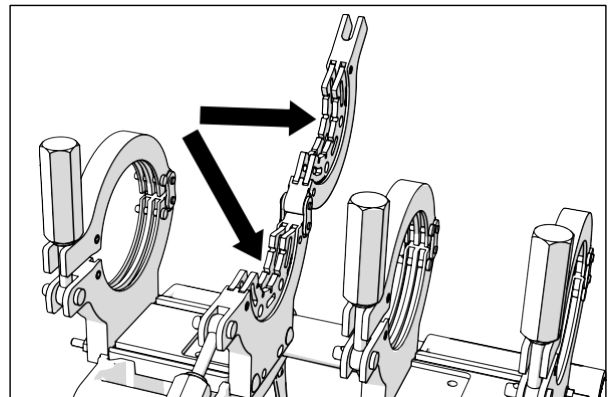

CD02708-03-20-23

- 4) Install the quick release pins into the jaws to retain the inserts.

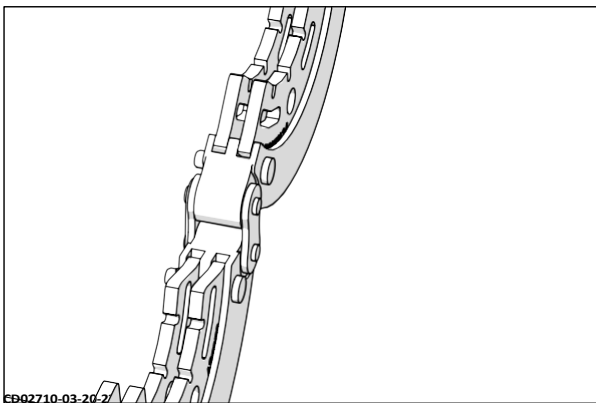
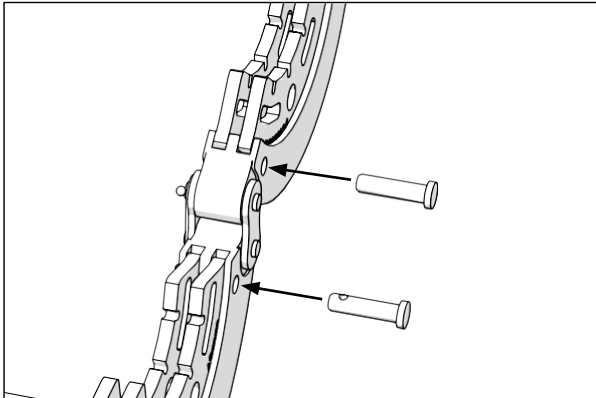

- 5) Repeat this to install inserts into the other jaws.

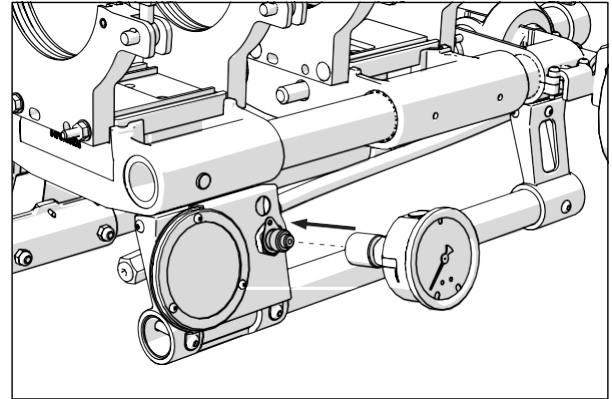

NOTICE: Do not pressure the machine greater than 100 PSI. Over-pressuring the gauge will damage the gauge and will no longer read pressure correctly.

Uninstall Gauge:

- 1) Open the carriage completely to remove pressure in the system.
- 2) Uninstall gauge from the DataLogger port.
- 3) Replace cap on the DataLogger port.

Polygon LT 100 PSI Auxiliary Gauge

The Polygon LT package includes an auxiliary gauge that is used to give increased visibility at low pressures.

Install Gauge:

- 1) Open the carriage completely to remove pressure in the system.
- 2) Remove the cap from the DataLogger port.
- 3) Install the gauge on the DataLogger port.

DataLogger® Graphs

What A DataLogger® Graph on the Polygon™ Should Look Like:

There are 3 graph plots that are created with the DataLogger.

The front-end plot shows the bead up and the heat/soak section of the fusion process. The green overlay on the plot shows the range of pressure vs time that the graph line should be in.

The heater removal plot shows the end of the heat/soak section and the heater removal section. The red overlay on the plot shows the range of time and pressure for when the carriage is opened, the heater is removed and the carriage is closed and fusion pressure applied.

The summary plot shows the entire fusion process from bead up to cooling. The purple overlay on the plot shows the range of time and pressure that the pipe is cooled under fusion pressure.

Using a manually operated machine with the DataLogger, the pressure line will appear irregular due to pressure dropping and reapplication of pressure being applied using the handwheel in order to maintain the recommended pressure. This irregular line will appear as a series of peaked lines.

If your fusion graphs do not stay within the overlays on the plots, review the operation of the machine and follow the recommended times given by the DataLogger.

TX05341-04-18

General Information

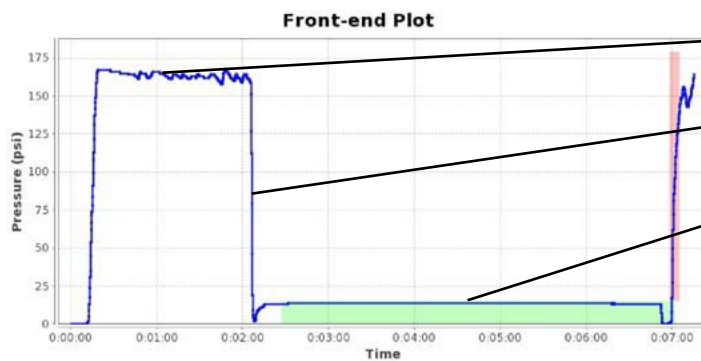

Bead up at recommended fusion pressure applied from the handwheel.

After bead up, reduce pressure to drag pressure.

Soak at drag pressure for the recommended soak time.

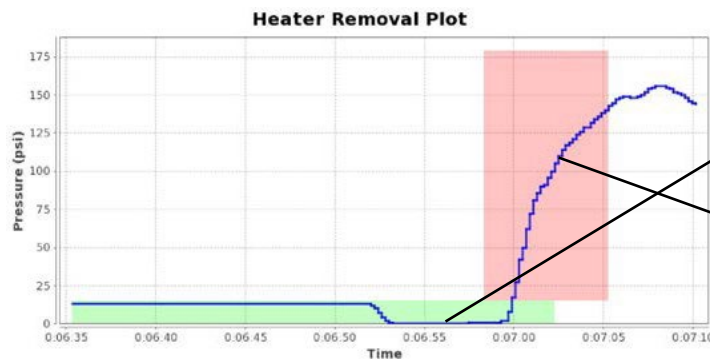

Carriage is opened and heater is removed.

Carriage is closed and pressure is increased to recommended fusion pressure.



Pipe is cooled at fusion pressure for recommended cooling time.

OPERATION - BUTT FUSION

Load Pipe

Polygon™

- 1) Ensure the pipe jaws are installed. If the pipe jaws are not installed, refer to section "[Change Polygon™ Jaws](#)" for instruction on changing the jaws. This application requires the pipe jaws.
- 2) Ensure both jaws have a 0° jaw angle. If the jaws are not set to 0°, loosen the clamp underneath the jaw and rotate the jaw so that the jaw angle indicator is aligned with 0° on the base. Placing a piece of pipe through both jaws will assist in aligning the two jaws.

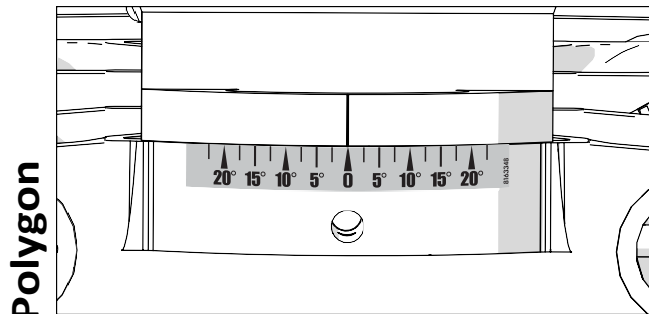

- 3) Select and install appropriate clamping inserts for the pipe size that is being fused.
- 4) Load pipe into the jaws allowing 1-1/8" (29mm) to protrude past the face of the jaw.

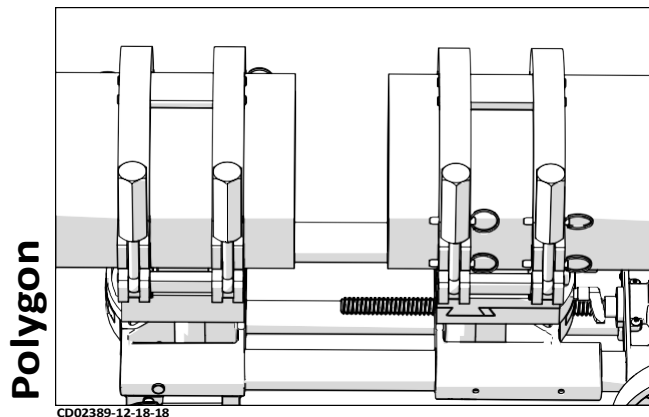

- 5) Tighten the clamp knobs on the outside jaws to prevent pipe from slipping. Hand tighten the inside clamp knobs to allow for HI/LO adjustment.

The clamp knobs are equipped with a ball thrust bearing, which permit the operator to develop high clamp forces with minimal effort.

NOTICE: When clamping, do not over-tighten the clamp knobs because machine damage can result. Check to see if there is space between the upper and lower jaws. If the two jaws are touching, do not continue to tighten.

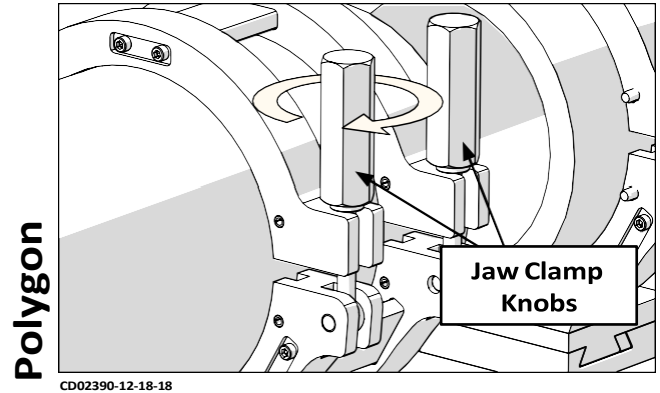

Polygon™ LT

- 1) Ensure the appropriate jaws are installed on the machine. If the jaws need to be reconfigured, refer to section "[Change/Remove Jaws \(Polygon LT\)](#)" for instructions for changing jaws.
- 2) Select and install appropriate clamping inserts for the pipe size that is being fused.
- 3) Insert the facer in between the two fully open jaws and insert pipe into the jaws allowing the pipe to come in contact with the blades of the facer.

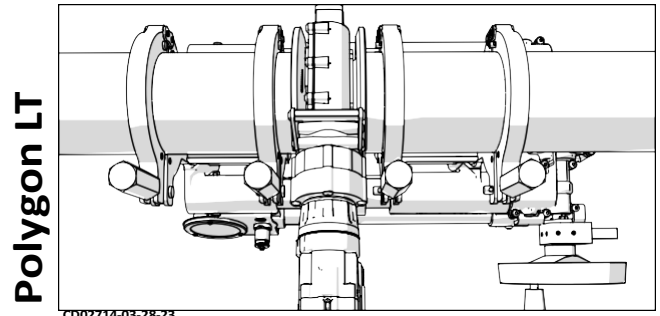

- 4) Tighten the clamp knobs on the outside jaws to prevent pipe from slipping. Hand tighten the inside clamp knobs to allow for HI/LO adjustment. Remove the facer.

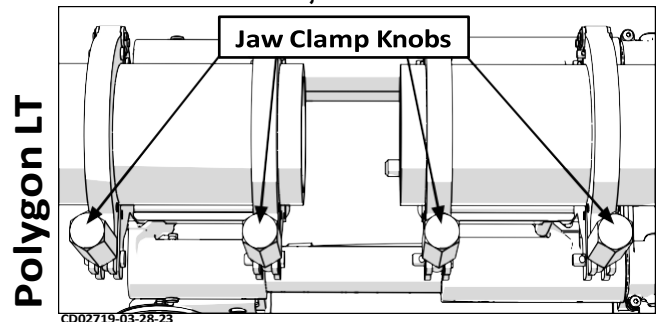

The clamp knobs are equipped with a ball thrust bearing, which permit the operator to develop high clamp forces with minimal effort.

NOTICE: When clamping, do not over-tighten the clamp knobs because machine damage can result. Check to see if there is space between the upper and lower jaws. If the two jaws are touching, do not continue to tighten.

Prepare Heater

⚠ DANGER

This heater is not explosion proof. Operation of heater in an explosive atmosphere without necessary safety precautions will result in serious injury or death.

When operating in an explosive atmosphere, the heater should be brought up to temperature in a safe environment, then unplugged before entering the explosive atmosphere for fusion.

- 1) Install butt fusion heater plates.

NOTICE: The heater should never be used without butt fusion heater plates installed. Refer to the [“Changing Heater Plates/Adapters”](#) section of this manual for installation procedure.

- 2) Place heater in insulated heater stand.
- 3) Plug heater into a proper power source. Refer to Heater Information Label for power information.

Polygon

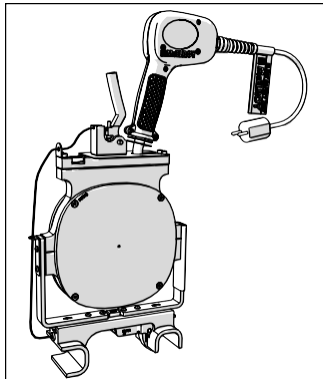

CD02419-1-24-19

Polygon LT

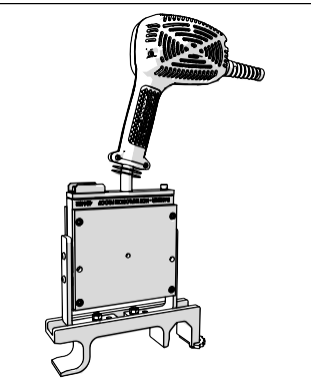

CD02711-03-20-23

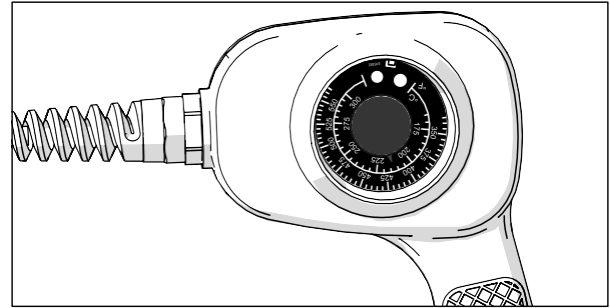

CD02152-2-21-18

The heater has a green indicator light which will flash on and off. This indicates that the controller is operating normally. If the green indicator is not flashing then the controller may not be operating properly. If this occurs, disconnect power and have the heater repaired by a McElroy Authorized Service Center.

The heater has a red indicator light on the handle at the bottom of the temperature scale. When the heater is plugged in and preheating, the red light glows steadily until the set temperature is reached. The red light then goes off and on as the heater maintains temperature.

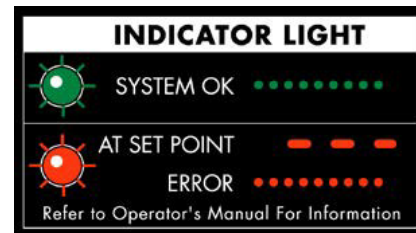

PH02571-2-21-18

If the heater is not operating properly, the control will attempt to turn the heater off and the red indicator light will flash rapidly. If this occurs, disconnect the power and take it to a McElroy Authorized Service Center for repair.

- 5) Allow heater to warm-up to operating temperature.

Prepare Facer

⚠ DANGER

Electric motors are not explosion proof. Operation of these components in an explosive atmosphere without necessary safety precautions will result in serious injury or death.

The Polygon and Polygon LT facer drill cannot be used manually and must not be used in an explosive atmosphere.

- 1) Inspect the facer blades on the blade holder for damage or dullness. Replace damaged or dull blades. Refer to [“Facer Blades”](#) in the Maintenance section for information about facer blades.
- 2) Install a charged battery in the drill.

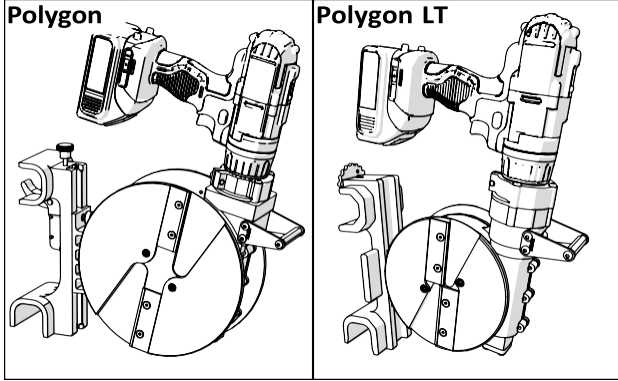

CD02387-12-17-18

CD02712-03-28-23

⚠ WARNING

Facer blades are sharp and can cut. Never attempt to remove shavings while the facer is running, or is in the facing position between the jaws. Use care when operating the facer, and when handling the unit.

NOTICE: Remove the battery from the drill before attempting any maintenance or adjustment of facer blades.

NOTICE: Never extend the facer blades beyond the inner or outer circumference of the facer.

Face Pipe

Ensure the facer guide rod bracket assembly is positioned in the middle so the pipe ends are inside the outer diameter of the blade holders.

Adjust the Facer Guide Rod Bracket Assembly (Polygon):

- 1) Pull up on the guide rod bracket assembly plunger to slide the facer in either direction. There are detents that the release fits in to lock the base in place.

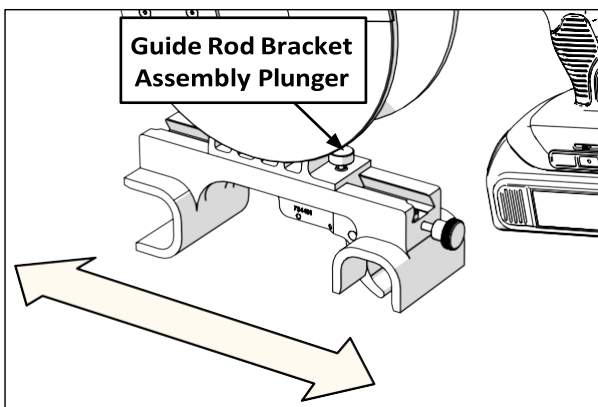

CD02393-12-18-18

Face Pipe:

- 2) Open the carriage and install the facer, ensuring the facer latches onto the carriage guide rod.

Polygon LT - Engage the facer latch on the guide rod

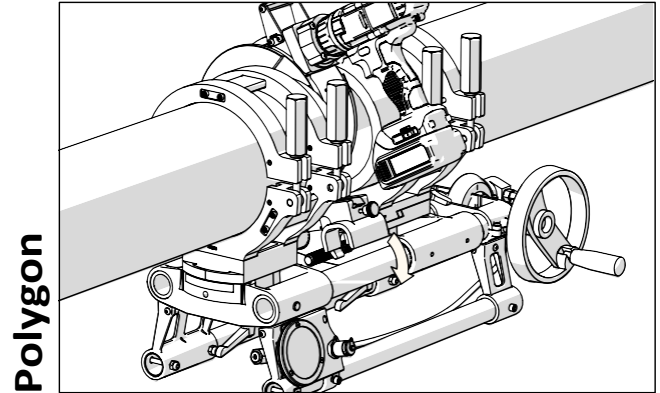

Polygon

CD02394-12-18-18

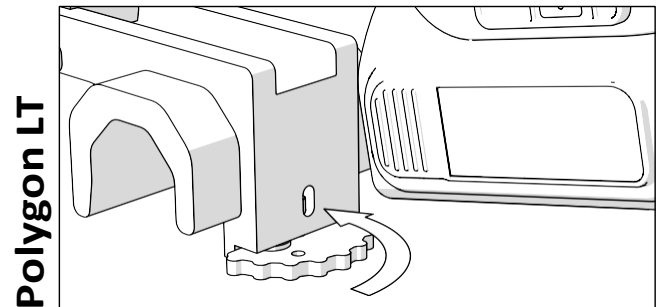

Polygon LT

CD02713-03-28-23

- 3) Squeeze the trigger with your left hand to turn on the facer.
- 4) Rotate the handwheel to close the carriage. Keep carriage pressure on the facer until both pipes produce a complete shaving about the circumference of the pipe.

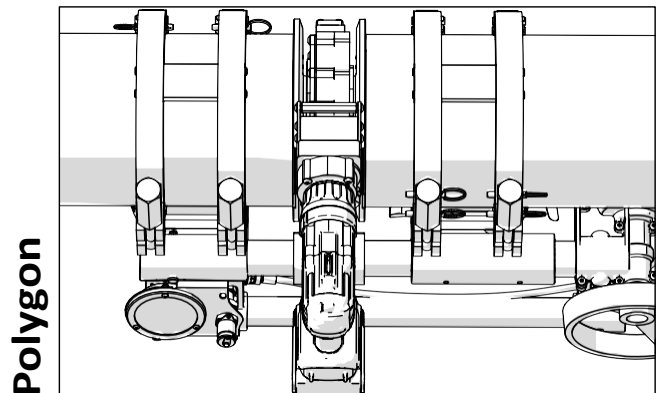

Polygon

CD02420-1-24-19

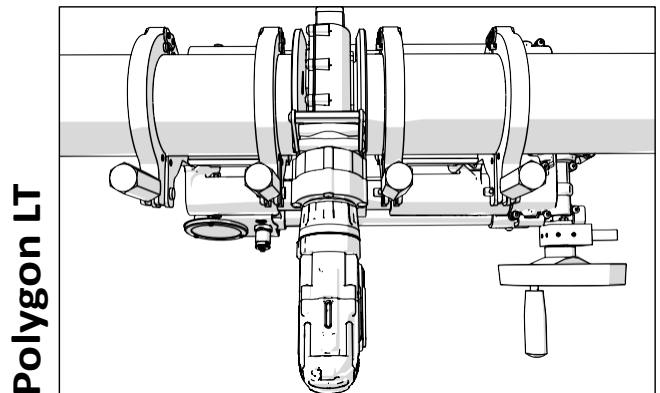

Polygon LT

CD02714-03-28-23

If the facer stalls, reduce the amount of pressure applied with the handwheel until it begins to cut again.

- 5) When the facer has faced a complete shaving, run the facer several revolutions to ensure that there are not chips hanging on the end of the pipe. Release the trigger on the facer.
- 6) Open the carriage using the handwheel.
- 7) **Polygon:** Push the guide rod bracket assembly lock plunger and use the drill handle and the auxiliary handle to lift the facer out of the carriage.

Polygon LT: Rotate the latch off the guide rod and remove the facer from the carriage.

Polygon

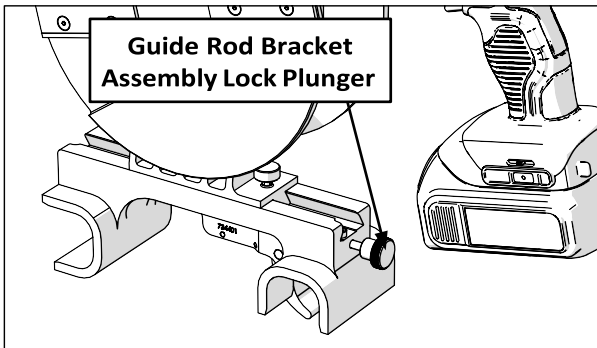

CD02395-12-18-18

Polygon LT

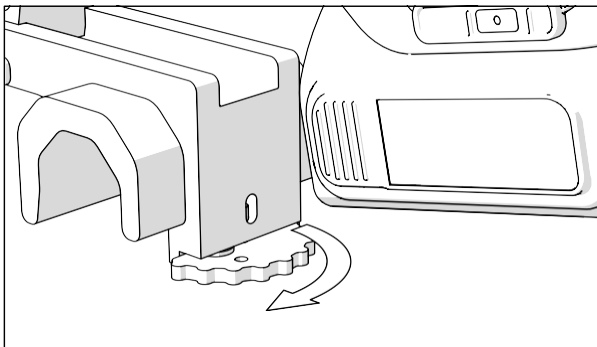

CD02715-03-28-23

- 8) Remove shavings and inspect both pipe ends for complete face off. If the face off is incomplete, reload pipe and reface the pipe ends.

Calculate Fusion Pressure

- 1) Use McCalc® app that is available for iOS, Android, Windows Phone and PC devices to calculate the fusion pressure required, the DataLogger, or printed weld parameters to determine the correct Bead up, heat Soak and Fusion/cooling pressure needed.

Check Alignment

- 1) Close the carriage until the ends of the pipe butt together.
- 2) Check pipes for alignment.

Polygon: If pipe is not lined up, the movable jaw can be adjusted laterally to align the pipe.

Polygon LT: If pipe is not lined up, tighten the clamp knob on the inner jaw of the pipe that is higher.

Ensure there is no unacceptable gap between the pipe ends. If there is unacceptable gap, reinsert facer and reface.

- 3) Close the carriage and check for slippage. Apply fusion pressure with the handwheel and inspect if the pipes slip.

Insert Heater

NOTICE: Incorrect heating temperature can result in questionable fusion joints. Check heater plates periodically with a pyrometer and make necessary adjustments.

Refer to [“Prepare Heater”](#) section for how to adjust heater temperature.

- 1) Check heater surface temperature with a pyrometer.

Refer to the pipe manufacturer’s recommendations or appropriate joining standard for proper heater temperature.

IMPORTANT: The dial thermometer on the heater indicates internal temperature which varies from the actual surface temperature.

The dial thermometer can be used as reference once the surface temperature has been verified and is never a substitute for actual surface temperature.

⚠ DANGER

This heater is not explosion proof. Operation of heater in an explosive atmosphere without necessary safety precautions will result in serious injury or death.

- 2) Use a clean dry lint free non-synthetic cloth to clean the butt fusion heater plates.

Ensure the heater guide rod bracket assembly is positioned in the middle so the pipe ends are inside the outer diameter of the heater plates.

- 3) **Polygon:** Push on the frame of the heater with a gloved hand to slide the heater horizontally. It has several detents that will lock the position as it is slid across.

Polygon LT: guide rod bracket assembly does not adjust.

CAUTION

The heater is hot and will burn clothing and skin. Keep the heater in its insulated heater stand or blanket when not in use, and use care when heating the pipe.

Polygon

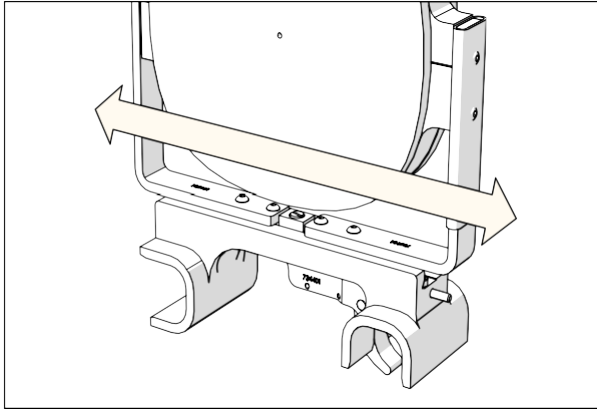

CD02421-1-24-19

- 4) Insert heater between pipe ends.
- 5) Ensure the guide rod bracket assembly engages the guide rod.

Heating the Pipe

- 1) Close carriage to bring pipe ends in contact with the heater.
- 2) Wait for manufacturer's recommended bead up.
- 3) After the proper bead-up, back off pressure to drag pressure or 0 PSI. Do not move the carriage handle and allow the heater to melt the pipe ends for the recommended soak time.

Fusing the Pipe

- 1) When the soak time is complete, quickly open the carriage enough to remove the heater.

Polygon: Actuate the heater release handle to unlock the heater from the carriage guide rod. Remove heater.

Polygon LT: Remove the heater

Polygon

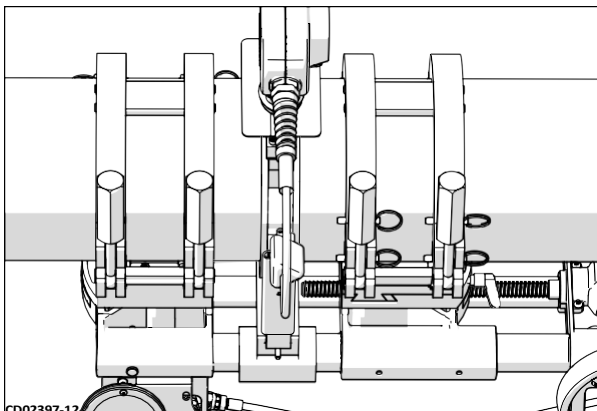

CD02397-17

Polygon LT

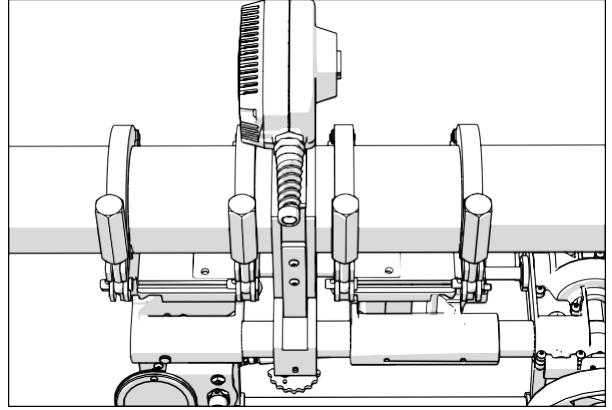

CD02716-03-28-23

- 2) Quickly inspect the pipe ends for proper melt.
- 3) Quickly close the carriage bringing the pipe ends together.
- 4) Rotate the handwheel until carriage pressure on the gauge reads the pipe manufacturer's recommended fusion pressure.
- 5) **Polygon:** Continue to add more pressure to maintain the fusion pressure on the gauge.

Polygon LT: Engage the brake to maintain position holding pressure on the joint.

Allow joint to cool under pressure according to pipe manufacturer's or appropriate joining standard's recommendations.

Polygon

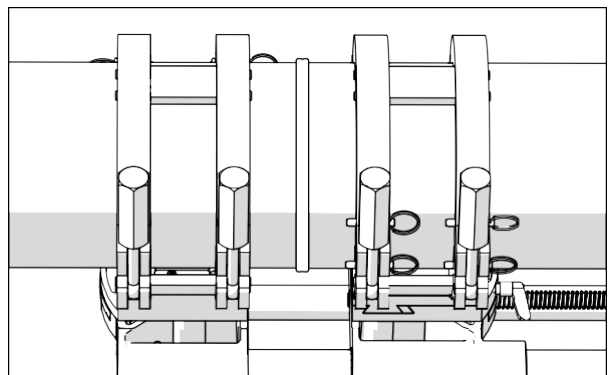

CD02398-12-18-18

Polygon LT

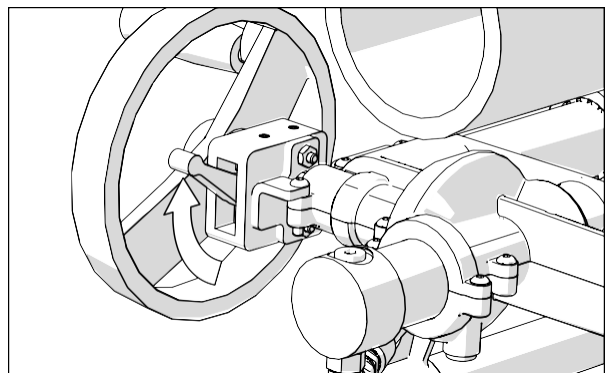

CD02718-03-28-23

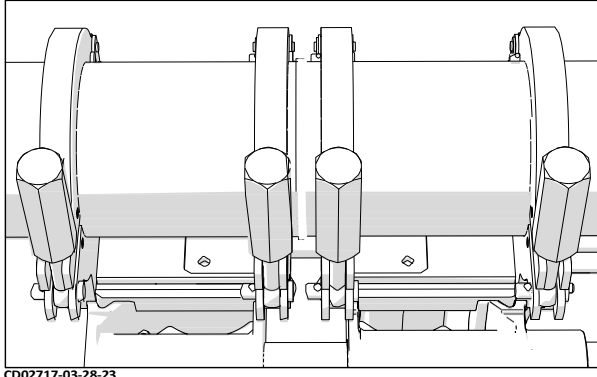

Remove Fused Pipe

- 1) Inspect the fusion joint for proper appearance.

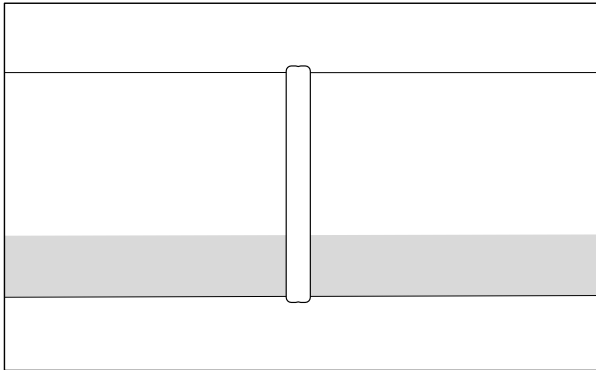

- 2) Open the clamps on the movable and fixed jaws.
- 3) Remove the fused pipe from the carriage.
- 4) Refer to the section [“Load Pipe”](#) to prepare for the next fusion.

OPERATION - MITERED FUSION (POLYGON)

Load Pipe

- 1) Ensure the pipe jaws are installed. If the pipe jaws are not installed, refer to section [“Change Polygon™ Jaws”](#) for instruction on changing the jaws. This application will require the pipe jaws.
- 2) Select and install appropriate clamping inserts for the pipe size that is being fused.
- 3) Rough cut the pipe ends to the approximate jaw angle desired.

NOTICE: Do not cut pipe while in the machine.

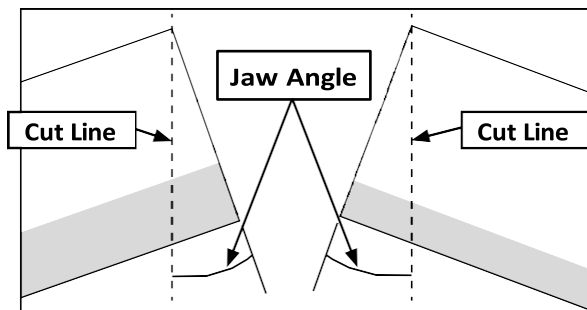

CD02165-2-21-18

- 4) Set the desired fusion angle. Each jaw will need to be adjusted to set the correct jaw angle based on the fusion angle. Refer to section [“Mitered Fusion Angles”](#) for instructions on how to set the jaw angles.

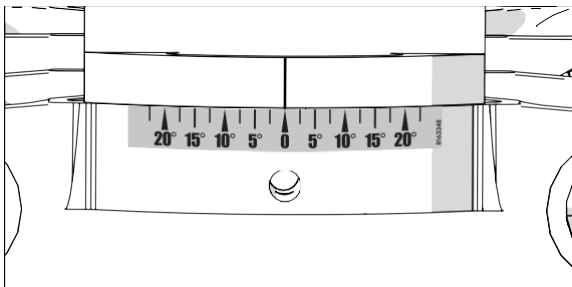

CD02388-12-18-18

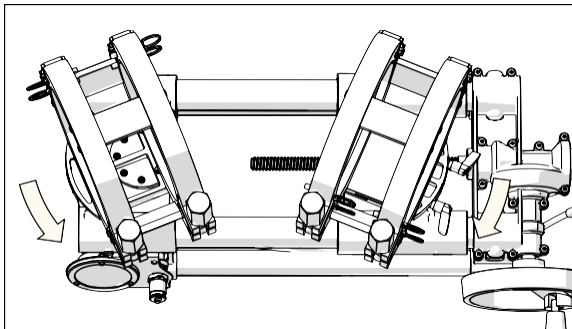

CD02399-12-21-18

- 5) Insert the facer between the jaws of the carriage. Load pipe into the jaws with the pipe ends close to the blade holders with approximately equal amount on both sides. Ensure the pipe is straight in the jaws to reduce pipe misalignment.

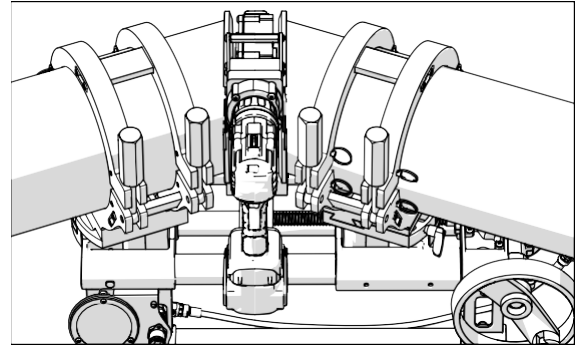

CD02400-01-03-19

- 6) Clamp the jaws by inserting the handle into the pit of the jaw, and rotating the handle up toward the jaw. If there is no tension during clamping, open the handle and rotate the tension knob then try to clamp again. Repeat this until the jaw clamps firmly on the pipe. Bring the pipe ends together under pressure to ensure there is no slippage.

IMPORTANT: Positioning the handle at 45° while in the pit of jaw is a good starting position for clamping the pipe.

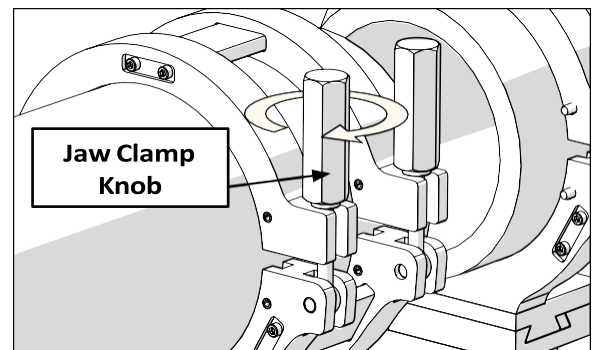

CD02149-2-21-18

Prepare Heater

⚠ DANGER

This heater is not explosion proof. Operation of heater in an explosive atmosphere without necessary safety precautions will result in serious injury or death.

When operating in an explosive atmosphere, the heater should be brought up to temperature in a safe environment, then unplugged before entering the explosive atmosphere for fusion.

- 1) Install butt fusion heater plates.

NOTICE: The heater should never be used without butt fusion heater plates installed. Refer to the [“Changing Heater Plates/Adapters”](#) section of this manual for installation procedure.

- 2) Place heater in insulated heater stand.
- 3) Plug heater into a proper power source. Refer to Heater Information Label for power information.

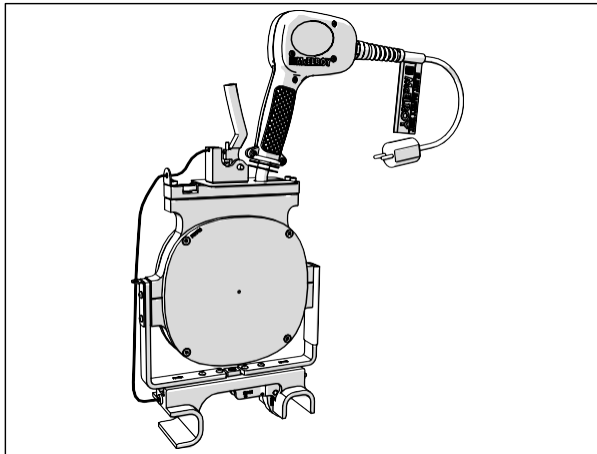

CD02419-1-24-19

Adjusting Heater Temperature:

- 4) Turn knob to desired temperature. Allow heater to reach temperature. Measure the heater surface temperature with a pyrometer. Any variance must be corrected to the pyrometer reading.

Loosen set screw in the knob. Turn knob to point to the temperature of the pyrometer reading. Tighten set screw in the knob.

Turn knob to desired temperature. Allow heater to stabilize at the new temperature (5 to 10 minutes) after adjusting.

The thermometer on the heater body indicates internal temperature and should be used as a reference only.

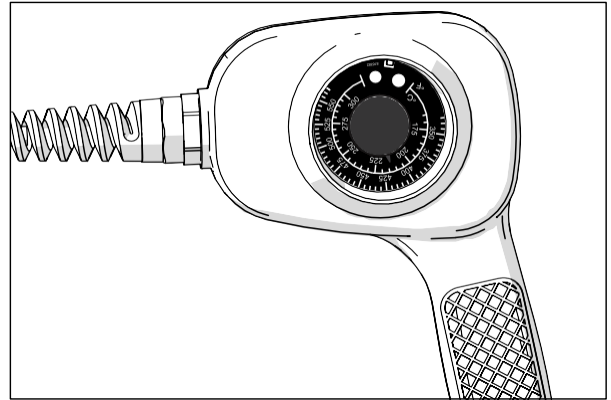

CD02152-2-21-18

The heater has a green indicator light which will flash on and off. This indicates that the controller is operating normally. If the green indicator is not flashing then the controller may not be operating properly. If this occurs, disconnect power and have the heater repaired by a McElroy Authorized Service Center.

The heater has a red indicator light on the handle at the bottom of the temperature scale. When the heater is plugged in and preheating, the red light glows steadily until the set temperature is reached. The red light then goes off and on as the heater maintains temperature.

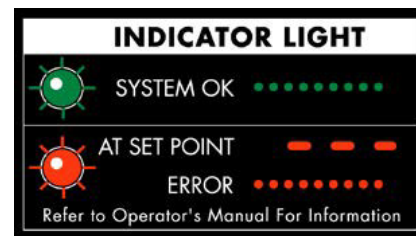

PH02571-2-21-18

If the heater is not operating properly, the control will attempt to turn the heater off and the red indicator light will flash rapidly. If this occurs, disconnect the power and take it to a McElroy Authorized Service Center for repair.

- 5) Allow heater to warm-up to operating temperature.

Prepare Facer

⚠ DANGER

Electric motors are not explosion proof. Operation of these components in an explosive atmosphere without necessary safety precautions will result in serious injury or death.

The Polygon™ facer drill cannot be used manually and must not be used in an explosive atmosphere.

- 1) Inspect the facer blades on the blade holder for damage or dullness. Replace damaged or dull blades. Refer to [“Facer Blades”](#) in the Maintenance section for information about facer blades.
- 2) Install a charged battery in the drill.

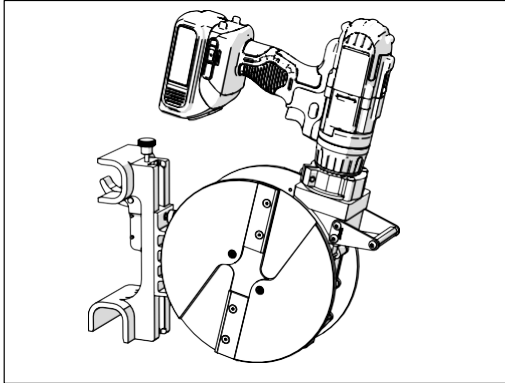

WARNING

Facer blades are sharp and can cut. Never attempt to remove shavings while the facer is running, or is in the facing position between the jaws. Use care when operating the facer, and when handling the unit.

NOTICE: Remove the battery from the drill before attempting any maintenance or adjustment of facer blades.

NOTICE: Never extend the facer blades beyond the inner or outer circumference of the facer.

Face Pipe

Ensure the facer guide rod bracket assembly is positioned so that the pipe ends are inside the outer diameter of the blade holders.

Adjust the Facer Guide Rod Bracket Assembly:

- 1) Pull up on the guide rod bracket assembly plunger to slide the facer in either direction. There are detents that the release fits in to lock the base in place.

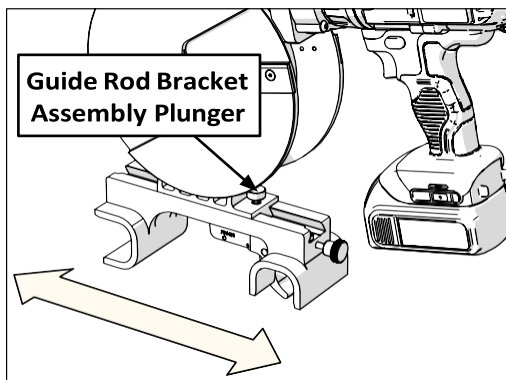

Face Pipe:

- 2) Open the carriage and install the facer, ensuring the facer latches onto the carriage guide rod.

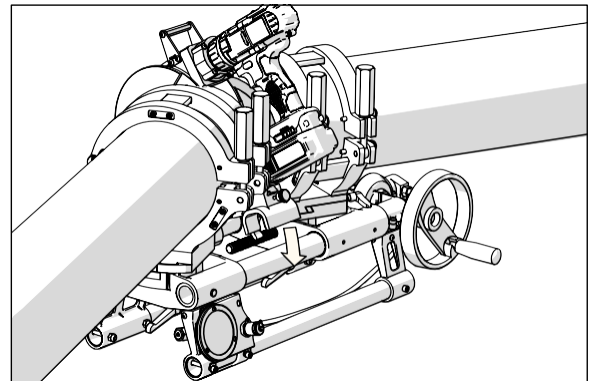

- 3) Squeeze the trigger with your left hand to turn on the facer.
- 4) Rotate the handwheel to close the carriage. Keep carriage pressure on the facer until both pipes produce a complete shaving about the circumference of the pipe.

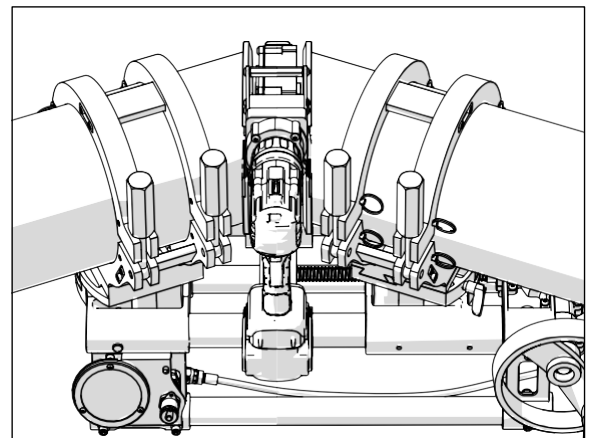

If the facer stalls, reduce the amount of pressure applied with the handle until it begins to cut again.

- 5) When the facer has faced a complete shaving, run the facer several revolutions to ensure that there are not chips hanging on the end of the pipe. Release the trigger on the facer.
- 6) Open the carriage using the handwheel.

- 7) Push the guide rod bracket assembly lock plunger and use the drill handle and the auxiliary handle to lift the facer out of the carriage.

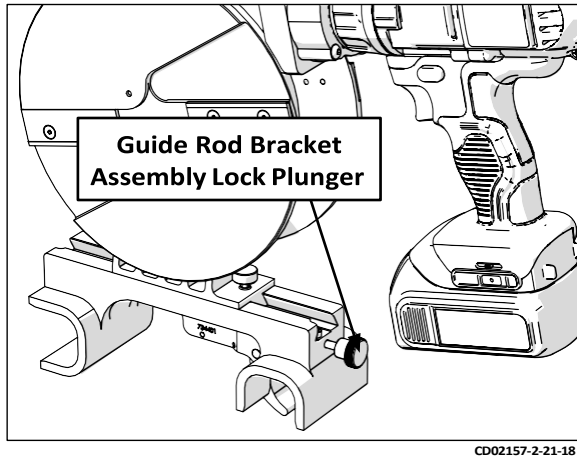

CD02157-2-21-18

- 8) Remove shavings and inspect both pipe ends for complete face off. If the face off is incomplete, reload pipe and reface the pipe ends.

Calculate Fusion Pressure

Mitered joints require more weld pressure than a straight butt weld due to more surface area to be welded. Contact Asahi/America for the correct weld pressure multiplier based on angle of weld.

Check Alignment

- 1) Close the carriage until the ends of the pipe butt together.
- 2) Check pipes for alignment.

If pipe is not lined up, the movable jaw can be adjusted laterally to align the pipe.

- 3) Loosen the movable jaw horizontal adjustment clamps. Align the pipes by sliding the jaw. Tighten the adjustment clamps.

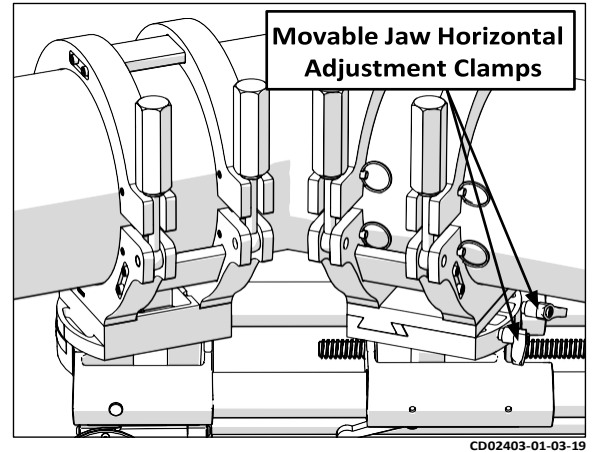

CD02403-01-03-19

Ensure any gap between the pipe ends is within the limits of the fusion procedure being used. If not acceptable, reinsert facer and reface.

- 4) Close the carriage and check for slippage. Apply fusion pressure with the handwheel and inspect if the pipes slip.

Insert Heater

NOTICE: Incorrect heating temperature can result in questionable fusion joints. Check heater plates periodically with a pyrometer and make necessary adjustments.

Refer to [“Prepare Heater”](#) section for how to adjust heater temperature.

- 1) Check heater surface temperature with a pyrometer.

Refer to the pipe manufacturer’s recommendations or appropriate joining standard for proper heater temperature.

IMPORTANT: The dial thermometer on the heater indicates internal temperature which varies from the actual surface temperature.

The dial thermometer can be used as reference once the surface temperature has been verified and is never a substitute for actual surface temperature.

! DANGER

This heater is not explosion proof. Operation of heater in an explosive atmosphere without necessary safety precautions will result in serious injury or death.

- 2) Use a clean dry lint free non-synthetic cloth to clean the butt fusion heater plates.

Ensure the heater guide rod bracket assembly is positioned so that the pipe ends are inside the outer diameter of the heater plates.

- 3) Push on the frame of the heater with a gloved hand to slide the heater horizontally. It has several detents that will lock the position as it is slid across.

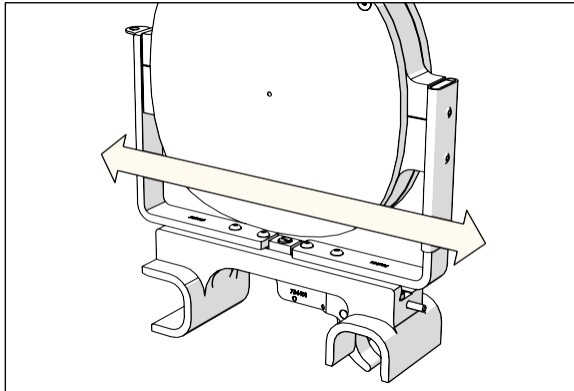

CD02421-1-24-19

CAUTION

The heater is hot and will burn clothing and skin. Keep the heater in its insulated heater stand or blanket when not in use, and use care when heating the pipe.

- 4) Insert heater between pipe ends.
- 5) Ensure the guide rod bracket assembly lock engages the guide rod.

Heating the Pipe

- 1) Close carriage to bring pipe ends in contact with the heater.
- 2) Wait for manufacturer's recommended bead up.
- 3) After the proper bead-up, Back off pressure to drag pressure or 0 PSI. Do not move the handwheel and allow the heater to melt the pipe ends for the recommended soak time.

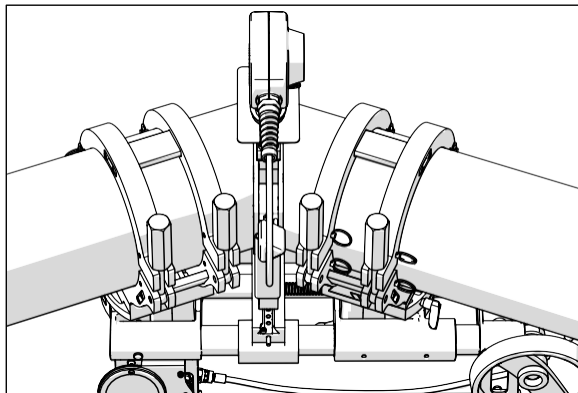

CD02405-01-03-19

Fusing the Pipe

- 1) When the soak time is complete, quickly open the carriage enough to remove the heater. Actuate the heater release handle to unlock the heater from the carriage guide rod. Remove heater.
- 2) Quickly inspect the pipe ends for proper melt.
- 3) Quickly close the carriage bringing the pipe ends together.
- 4) Rotate the handwheel until carriage pressure on the gauge reads the pipe manufacturer's recommended fusion pressure.
- 5) Continue to add more pressure to maintain the fusion pressure on the gauge.

Allow joint to cool under pressure according to pipe manufacturer's or appropriate joining standard's recommendations.

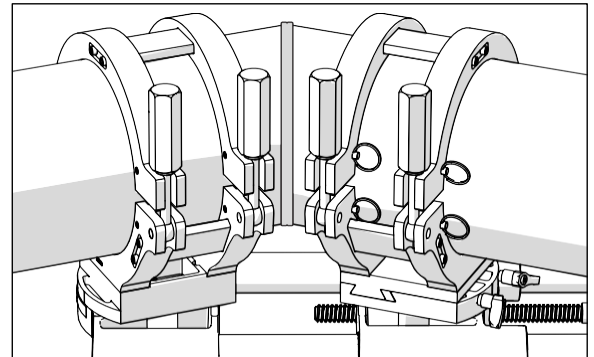

CD02172-2-21-18

Remove Fused Pipe

- 1) Inspect the fusion joint for proper appearance.
- 2) Open the clamps on the movable and fixed jaws.
- 3) Remove the fused pipe from the carriage.

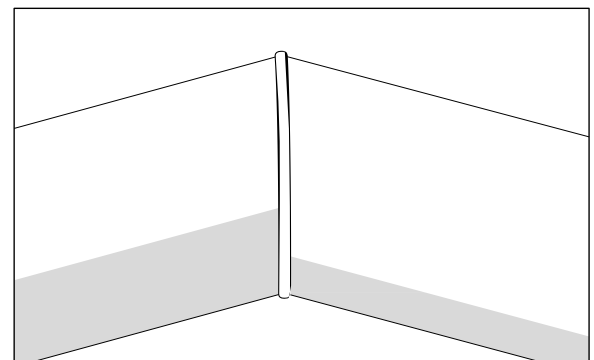

CD02173-2-21-18

- 4) Refer to "[Load Pipe](#)" in this section to prepare for the next mitered fusion.

STORAGE/TRANSPORT

Storage/Transport Polygon

A storage/transport case is available to store the Polygon™ fusion machine package. The case has wheels for mobility and carrying handle options that aid in loading and unloading. Foam inserts inside the case provide storage locations for each component of the package.

Refer to the illustrations for component locations.

- 1) Close the carriage and open the jaws. Place the machine in the case as shown with the upper jaws laying to the right of the machine.
- 2) Lock the heater and facer to the heater/facer stand. Ensure the facer is slid to the forward position on the facer guide rod bracket assembly. Place heater/facer stand into the case with the heater toward the Polygon™.

NOTICE: Ensure the heater is cool before inserting the heater/facer stand into the case. Damage to the foam inserts could occur.

There is an additional insert that lays on top of the bottom insert of the case.

Refer to the illustrations for component locations.

- 3) Place the drill battery into the case.
- 4) Place the battery charger into the case.
- 5) There are three pockets in the top insert to hold a set of jaw inserts. Each pocket can hold a set of (4) jaw inserts. When the socket fusion foam is removed, one set of jaw inserts can be stored.

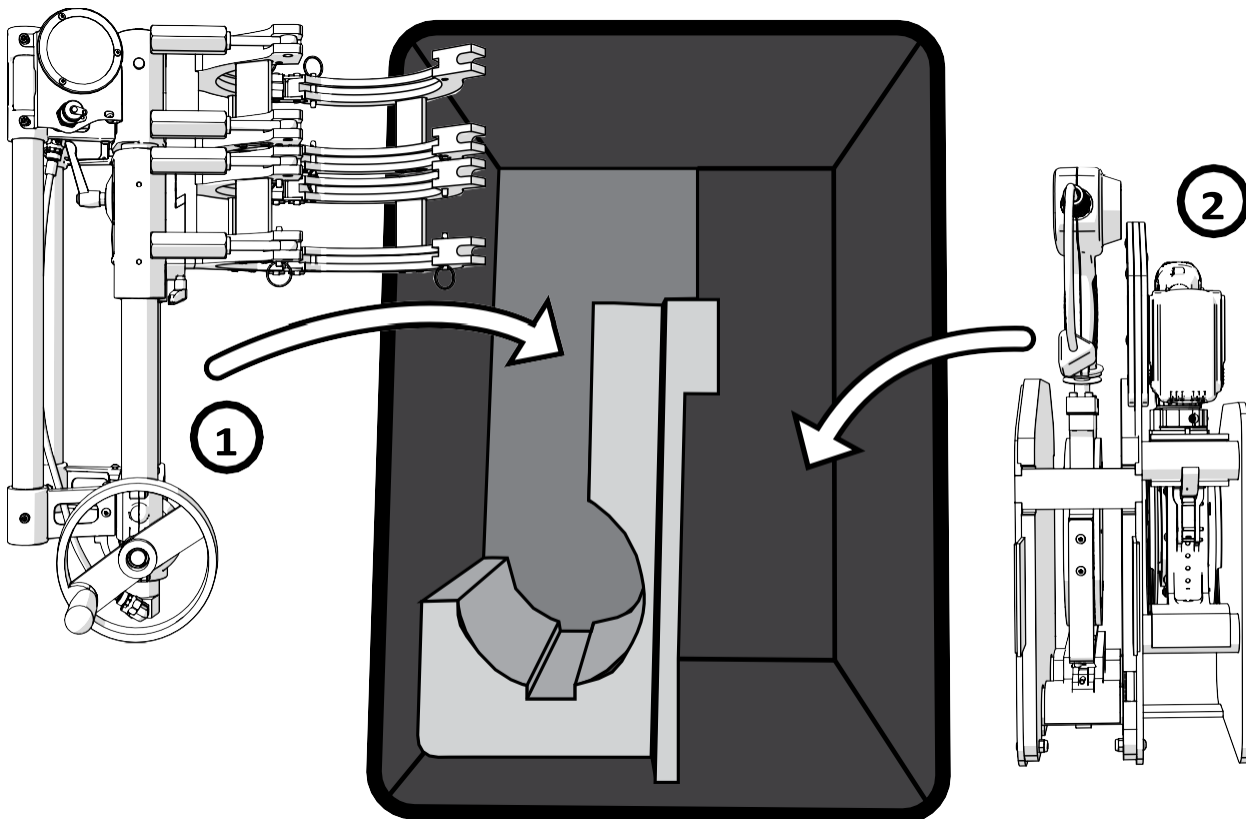

There are two socket fusion jaw foams that can be removed to store the socket fusion jaws.

- 6) Tighten the jaw until the jaws are close together. Remove the back up bar from the jaw. Insert the jaw into the top insert with the back of the jaw toward the bottom.
- 7) Tighten the jaw until the jaws are close together. Insert into the top insert with the back of the jaw toward the bottom.
- 8) Place the back up bar into the top insert.

- 9) Place the top insert into the case resting on the bottom insert. Close the lid and close all lid latches.

TX05391-01-28-19

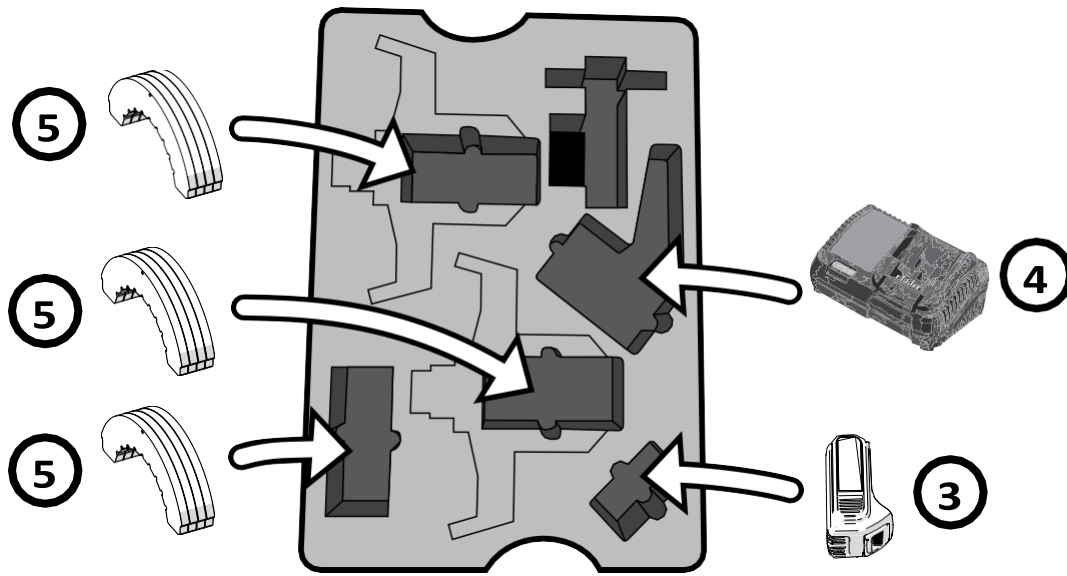

Insert with Socket Fusion Jaw Foam

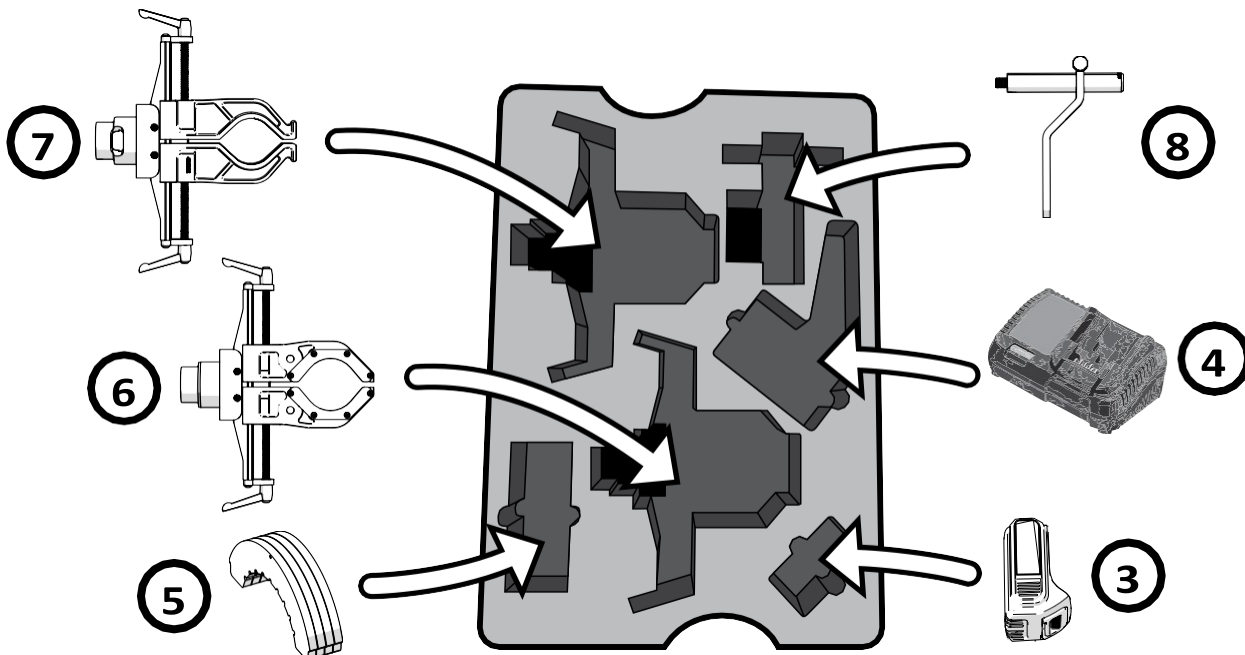

Insert with Socket Fusion Jaw Foam Removed

Storage/
Transport

Storage/Transport Polygon LT

A storage/transport case is available to store the Polygon™ LT fusion machine package. The case has wheels for mobility and carrying handle options that aid in loading and unloading. Foam inserts inside the case provide storage locations for each component of the package.

Refer to the illustrations for component locations.

- 1) Place the battery charger into the case.
- 2) Place the drill battery into the case.
- 3) Place the 100 PSI accessory gauge into the case.
- 4) There are eight pockets in the case to hold a set of jaw inserts. Each pocket can hold a set of (16) jaw inserts. Jaw insert sets are sold separately.

- 5) Open the carriage and unclamp the jaws. Rotate the clamps down and position the upper jaws on top of the lower jaws. Fold in the handle on the handwheel. Place the machine in the case as shown with the upper jaws laying to the right of the machine.
- 6) Lock the heater and facer to the heater/facer stand. Place heater/facer stand into the case as shown below.

NOTICE: Ensure the heater is cool before inserting the heater/facer stand into the case. Damage to the foam inserts could occur.

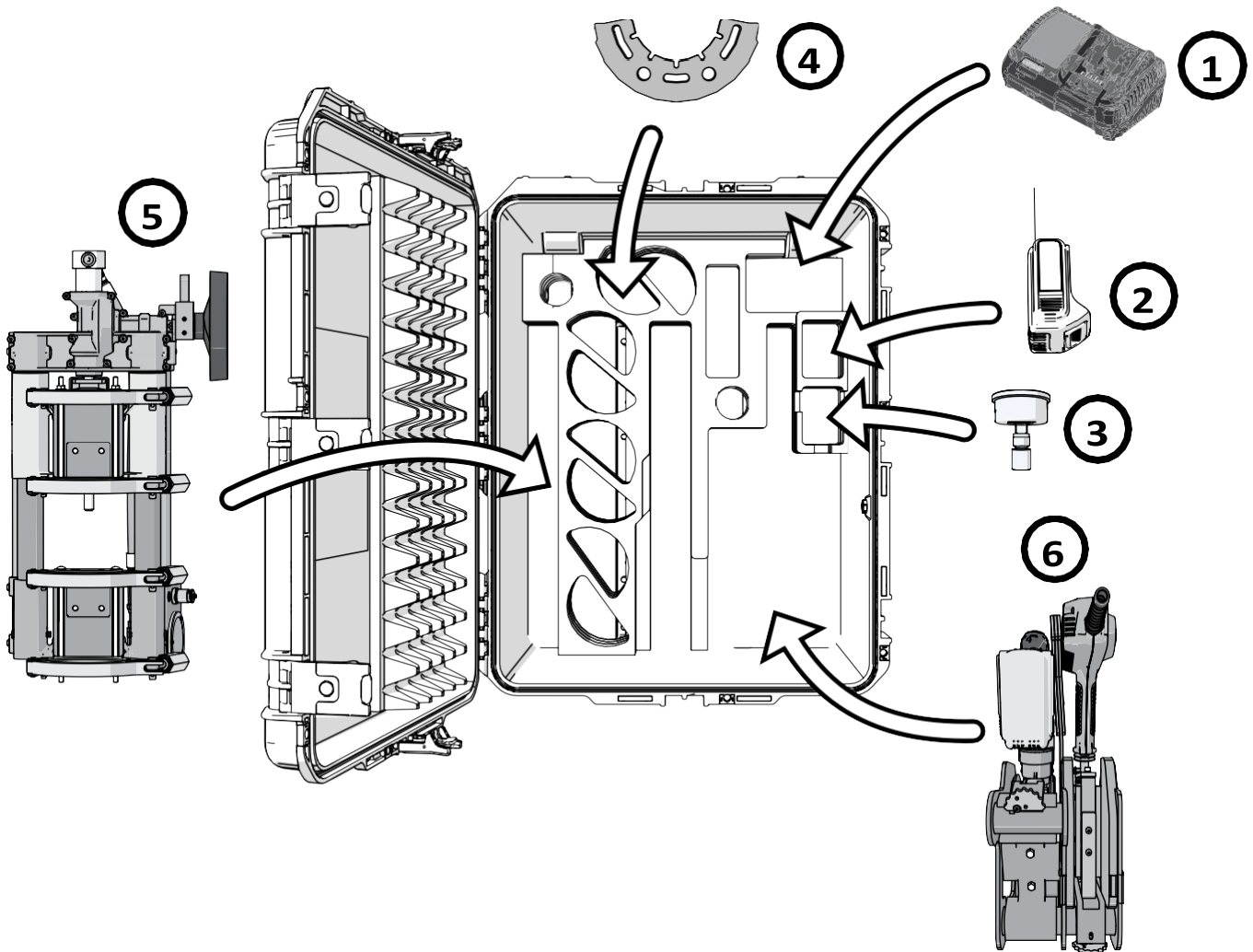

MAINTENANCE

Task	As Needed	Daily	Monthly	Yearly
Clean Machine	•			
Check Machine Operation		•		
Fasteners Are Tight			•	
Changing Heater Plates/Adapters	•			
Facer Blades	•			
Change Hydraulic Fluid				•
Change Gear Oil				•

Preventative Maintenance

To insure optimum performance, the machine must be kept clean and well maintained.

With reasonable care, this machine will give years of service. Therefore, it is important that a regular schedule of preventive maintenance be kept.

Store machine inside, out of the weather, whenever possible.

Clean Machine

- 1) Clean the machine with soap and water as needed.
Do not pressure wash.

Check Machine Operation

- 1) Open and close the carriage of the machine. If the machine has resistance opening or closing, inspect the carriage screw for debris in the threads and brush any debris out of the threads.
- 2) Close the carriage to the end of travel. Build pressure on the gauge, if the machine does not build pressure, check for fluid leakage and if the hydraulic fluid is full.
Inspect the gauge to ensure it is working properly.
- 3) Inspect the jaw clamps for proper operation. Replace any damaged jaw clamps.

Fasteners Are Tight

- 1) Inspect all machine fasteners for tightness. Tighten any loose fasteners.

Changing Heater Plates/Adapters

The heater body of this assembly is not coated. Coated heater plates/adapters are available for all

fusion applications. Heater plates/adapters are installed with stainless steel cap screws.

Care should be taken to assure that the heater adapters are seated on the heater body, and that there is no foreign matter trapped between these surfaces.

IMPORTANT: Do not over-tighten the bolts.

The surface of the heater adapters are coated with an anti-stick coating.

NOTICE: Only install heater adapters when the heater is cool.

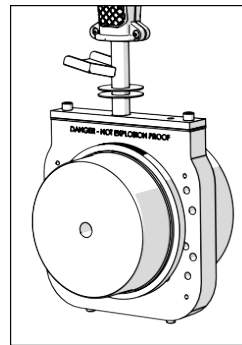

CD02174-2-21-18

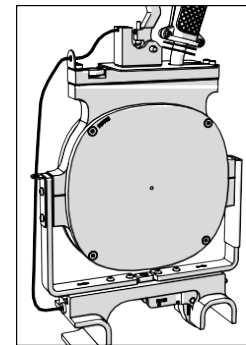

CD02419-1-24-19

Polygon LT

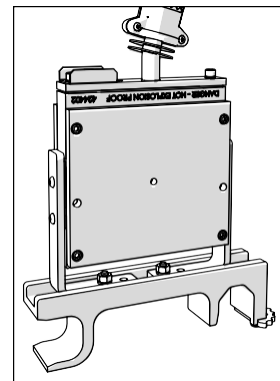

CD02711-03-20-23

Facer Blades

Blades bolt directly to the blade holder and should be inspected for damage and sharpness.

- 1) Dull or chipped blades must be replaced.

NOTICE: Never extend the blade beyond the inner or outer circumference of the facer.

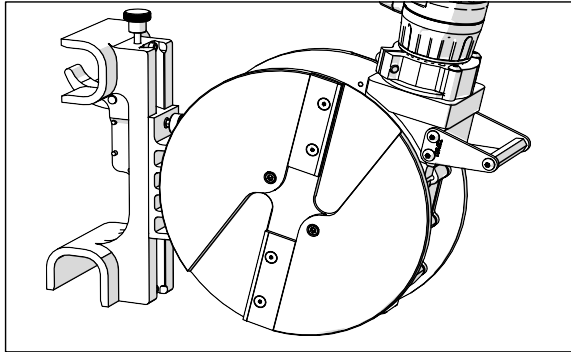

CD02387-12-17-18

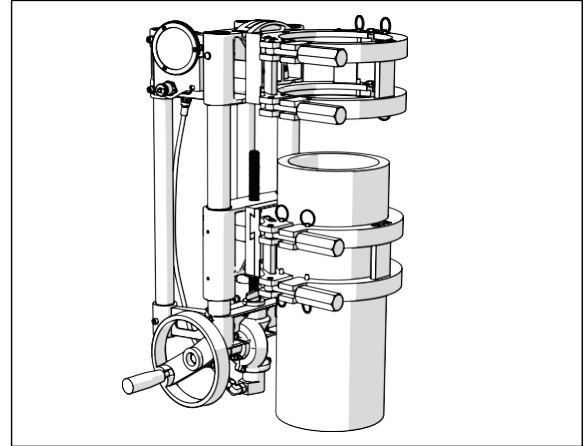

CD02407-1-3-19

- 9) Open the carriage against the flat surface so the cylinder is fully extended.
- 10) Remove the plug on the tee fitting behind the pressure gauge. Allow air to escape.

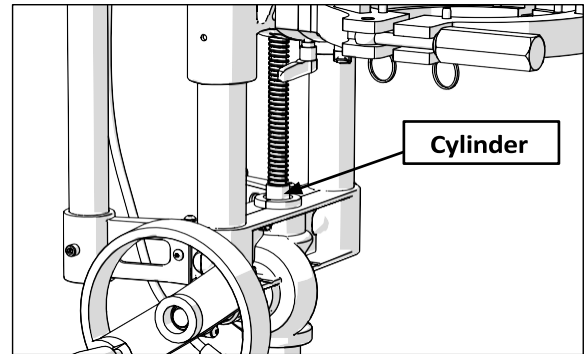

CD02408-1-3-19

Change/Fill Hydraulic Fluid

Polygon:

If the Polygon™ doesn't build pressure properly when closing the carriage, the hydraulic fluid is low or empty.

- 1) Open the carriage completely.
- 2) Position machine with the fixed jaw end up.
- 3) Loosen the plug on the tee fitting behind the pressure gauge.

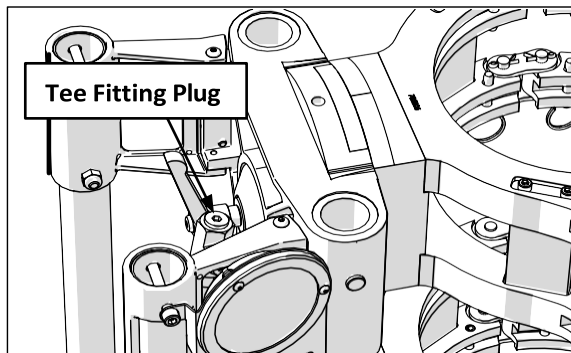

CD02406-01-03-19

- 4) Drain oil into a drain pan.
- 5) Fill with new and clean VG-46 hydraulic oil with the tee fitting port up.
Fill until oil reaches the start of the threads of the tee fitting.

- 6) Insert the plug into the tee and tighten the plug.

To bleed the air from the line:

- 7) Position machine with the fixed jaw end up.
- 8) Load a piece of pipe in the movable jaw of the machine with the pipe resting on a flat surface.

- 11) Fill the port to the start of the threads of the tee fitting.
- 12) Insert the plug into the tee and tighten the plug.
- 13) Cycle the handwheel back and forth approximately a half a turn ending with the carriage open against the flat surface and cylinder fully extended.
- 14) Remove the plug on the tee fitting and allow air to escape.
- 15) Repeat steps 11 through 14 until the air is bled.

Polygon LT:

If the Polygon™ LT doesn't build pressure properly when closing the carriage, the hydraulic fluid is low or empty.

- 1) Open the carriage completely.
- 2) Loosen the plug on the top of the hydraulic cylinder.

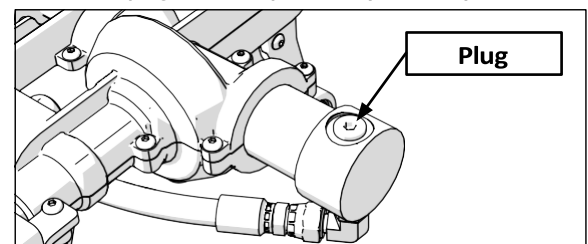

CD02725-04-03-23

- Loosen the plug on the tee fitting behind the pressure gauge.

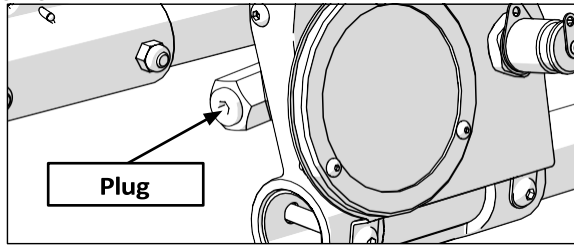

- Drain oil into a drain pan.
- Fill with new and clean VG-46 hydraulic oil into the top port of the hydraulic cylinder.

Fill until oil starts to come out of the tee behind the gauge. When it does, insert the plug into the tee and tighten the plug.

Resume filling until the oil reaches the threads of the top port.

- Insert the plug into the top port and tighten the plug.

To bleed the air from the line:

- Position machine on a flat surface.
- Ensure the hydraulic fluid is full. If not full, fill referring to the previous instructions.
- Cycle the handwheel back and forth applying pressure and ending with the carriage open fully.
- Remove the plug on the top of the hydraulic cylinder and allow air to escape. Re-install plug.
- Repeat steps 8 through 10 until the air is bled.

Change/Fill Gear Oil

- Remove the 13 screws securing the gear box top cover.

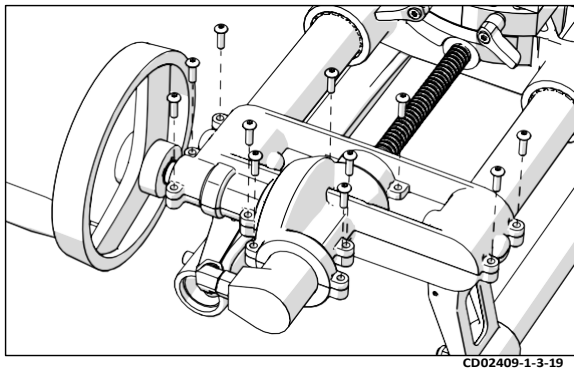

- Lift off the top cover and drain the oil into a clean drip pan.

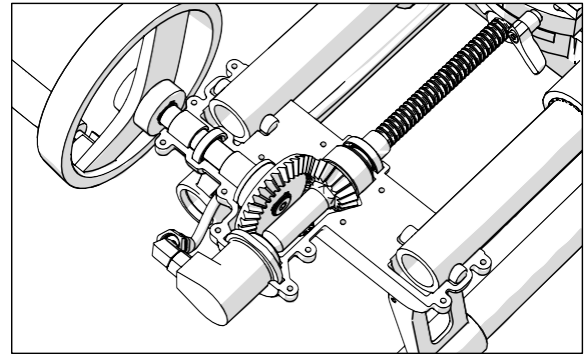

- Inspect drained oil for any debris.

If debris is present in the oil, the gear box may have some damage inside. Contact McElroy Technical Services for assistance in addressing the gear box.

- Scrape and clean old RTV material from the cover mating surfaces.

To fill the gear box:

- Clean out the gear box interior of any debris. Fill the gear box cavity 2/3 full with new clean gear oil (80/90W).
- Apply 1/8" bead of RTV around the mating surface of the top of the cover. Refer to the illustration below for location.

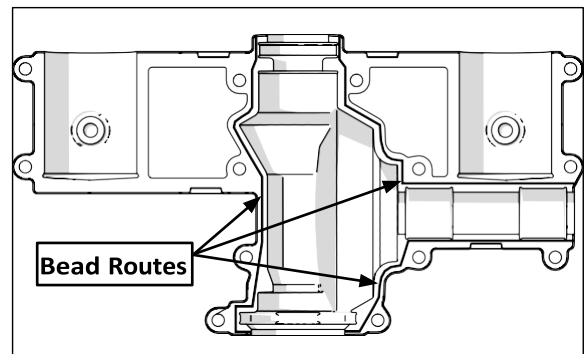

- Place the top cover on the gear box.
- Install and tighten the 13 screws to secure the top cover of the gear box.
- Check for leaks around the cover.

SPECIFICATIONS

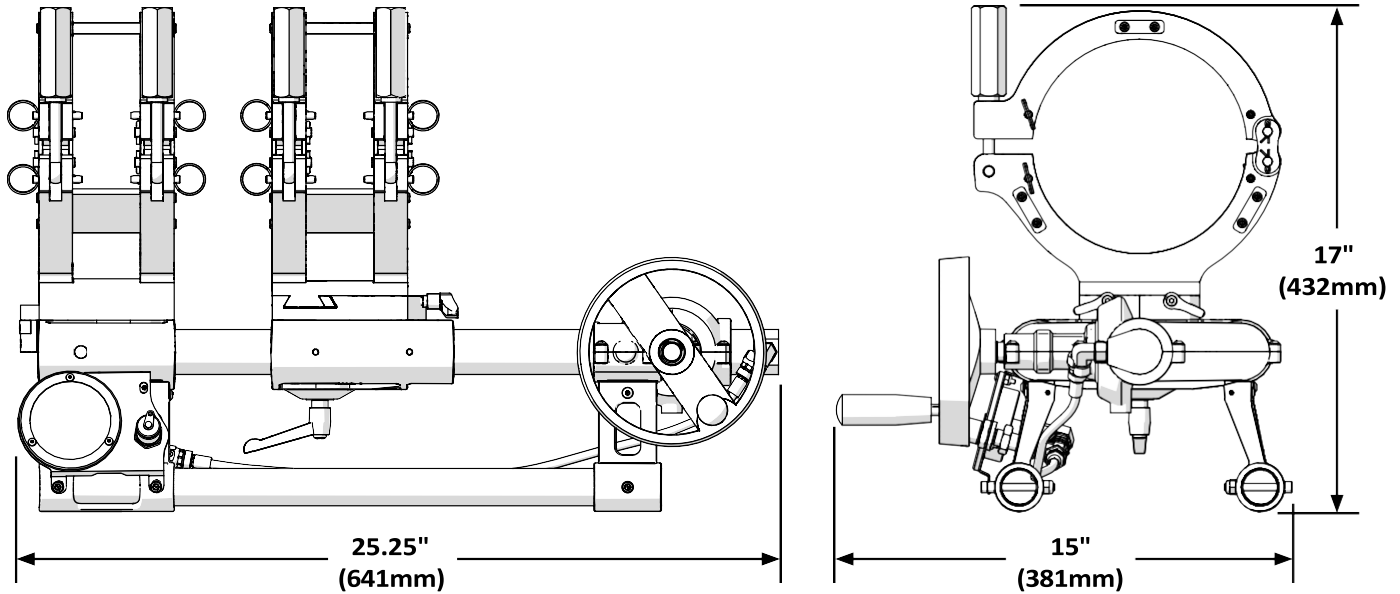

Polygon Specifications

Polygon™ Specifications

- Models:** A729801 - 120V Machine Package
A729802 - 240V Machine Package
A729803 - 120V High Force Machine Package
A729804 - 240V High Force Machine Package
A729805 - 120V Machine Package with Spider™ Jaws

- Capacity:** Fuses Pipe Sizes 63mm - 180mm (2" - 7")
Fuses Mitered Angles - 0 - 45°

- Weight:** Machine: 50.7 lbs. (23.0 Kg)
Heater: 16.3 lbs. (7.4 Kg)
Facer: 17.5 lbs. (7.9 Kg)

- Dimensions:** Length: 25.25" (641mm)
Width: 15" (381mm)
Height: 17" (432mm)

- Power:** Heater Power: 1,600 Watt

- Hydraulics:** Maximum Gauge Pressure: 400 PSI (Low Force)
2000 PSI (High Force)

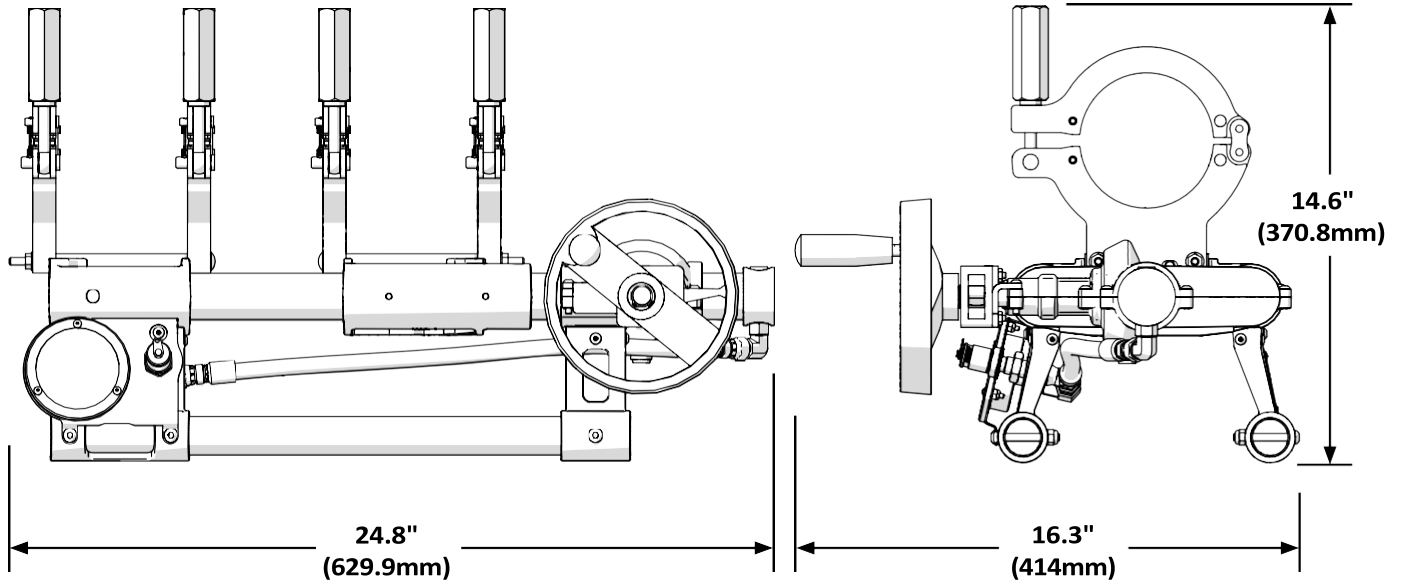

Polygon LT Specifications

Polygon™ LT Specifications

Models: A04P0978372 - Polygon LT Machine Package

Capacity: Fuses Pipe Sizes 20mm - 110mm (1/2" - 3 1/2")

Weight:

Machine:	30.7 lbs. (13.9 Kg)
Heater:	6.1 lbs. (2.8 Kg)
Facer:	18.3 lbs. (8.3 Kg)

Dimensions:

Length:	24.8" (629.9mm)
Width:	16.3" (414mm)
Height:	14.6" (370.8mm)

Power:

Heater Power:	100-120V, 1,200 Watt
Heater Plug Type:	NEMA 5-15P

Hydraulics:

Maximum System Pressure:	250 PSI (17.2 BAR)
Fusion Pressure:	250 PSI (17.2 BAR)



Tel: 781-321-5409 • Fax: 800-787-6861 • Toll Free: 800-343-3618
www.asahi-america.com • asahi@asahi-america.com
Direct Sales: East: 800-232-7244 / Central: 800-442-7244 / West: 800-282-7244