



## Pneumatic Globe Control

### Specifications

<b>Sizes:</b>	1/2" - 4"
<b>Materials:</b>	PVC, PP, PVDF and PTFE
<b>Model:</b>	Flanged (ANSI)
<b>Stem Seal:</b>	PTFE Bellows
<b>Valve Seal:</b>	FKM, EPDM, PTFE encapsulated FKM
<b>Flow Char.:</b>	Linear or equal percentage
<b>Rangeability:</b>	1: 50 for 1/2" - 3", 1: 30 for 4"
<b>Temp. Range:</b>	PVC 32- 140° F, PP -5 - 175° F PVDF -5 - 265° F, PTFE -5 - 284° F

### Standard Features (Sizes 1/2" - 4")

- Precise flow control
- Solid thermoplastic valve body provides excellent corrosion resistance
- PTFE bellows stem seal eliminates old style packing glands and minimizes maintenance
- Positive bubble-tight shut-off
- Plug and seat can be changed to accommodate a variety of valve coefficients (Cv)
- Plug (trim) can be characterized (linear or equal percentage) per requirements. (See below)
- No metal to media contact
- Extremely corrosion resistant actuator constructed of glass-filled polyester (PEG) with stainless steel trim
- Maximum required air pressure is 90psi
- 3-15psi direct acting for sizes up to 1" and 6.1 CV maximum. Larger valve sizes and CV's require positioner.

### Options

- 3-15psi pneumatic positioner
- 4-20 mA electro-pneumatic positioner
- 4-20 mA output transmitter
- Extra (auxiliary) limit switches

### Parts List (Sizes 1/2" - 4")

PARTS			
NO.	Description	PCS.	MATERIAL
1	Pneumatic Actuator	1	Polyester Glass Filled (PEG)
2	Actuator Spring	1	Coated Steel
3	Diaphragm	1	BUNA-N (Nitrile)
4	Actuator Valve Stem	1	316 Stainless Steel
5	Air Connection	1	1/4" FNPT
6	Actuator Standoffs	2	316 Stainless Steel
7	Position Indicator	1	Nylon Coated Steel
8	Bellows Seal O-Ring	1	EPDM, FKM, PTFE Encapsulated FKM
9	Bellows Housing	1	EPDM, FKM, PTFE Encapsulated FKM
10	Body O-Ring	1	EPDM, FKM, PTFE Encapsulated FKM
11	Bellows	1	PTFE
12	Seat O-Ring	1	EPDM, FKM, PTFE Encapsulated FKM
13	Valve Seat	1	PVC, PP, PVDF, PTFE
14	Valve Plug	1	PVC, PP, PVDF, PTFE
15	Valve Body	1	PVC, PP, PVDF, PTFE

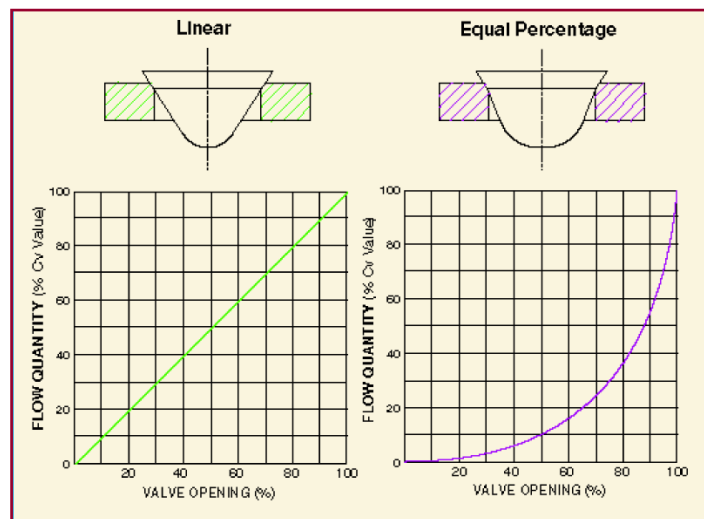

### Sample Specification

All thermoplastic modulating control valves shall be of the globe valve design. Valves shall have interchangeable seat and plugs to accommodate various flow coefficients (Cv) and flow characteristics shall be either linear or equal percentage. Stem seal shall be PTFE and of the bellows design. Pneumatic actuator shall be constructed of glass-filled polyester (PEG) with stainless steel trim. Actuator shall have 1/4" FNPT air connections and a visual position indicator. PVC shall conform to ASTM D1784 Cell Classification 12454-A, PP conforming to ASTM D4101 Cell Classification PPO210B67272, and PVDF conforming to ASTM D3222 Cell Classification Type II, and PTFE shall conform to PTFE 1600, as manufactured by Asahi/America, Inc.

**ASAHI/AMERICA RECOMMENDS THE USE OF AV GASKETS FOR THIS PRODUCT LINE**

### Caution

- Never remove valve from pipeline under pressure.
- Always wear protective gloves and goggles.

# Globe Control Valves

PVC/PP

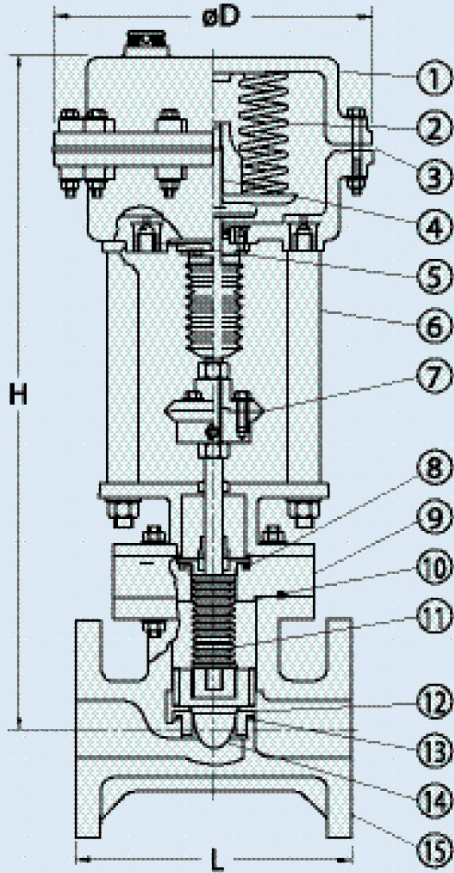

PVDF/PTFE

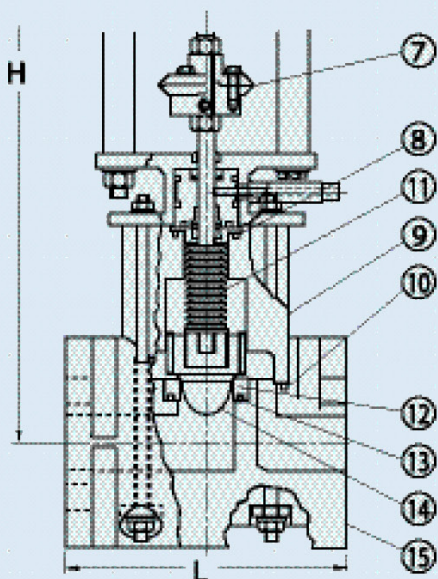

## Dimensions (in.)

NOMINAL SIZE		PVC, PP			PVDF, PTFE		
INCHES	mm	L	H	D	L	H	D
1/2	15	3.35	16.54	8.66	5.12	17.71	8.66
3/4	20	3.74	16.54	8.66	5.91	17.91	8.66
1	25	4.33	16.73	8.66	6.30	17.91	8.66
1-1/4	32	5.31	16.93	8.66	7.09	18.11	8.66
1-1/2	40	7.48	17.13	8.66	7.87	18.31	8.66
2	50	7.87	18.51	8.66	9.06	18.50	8.66
2-1/2	65	8.66	18.70	8.66	11.42	18.70	8.66
3	80	9.45	20.08	8.66	12.20	19.88	8.66
4	100	11.42	20.28	8.66	13.78	20.37	8.66

## Operating Pressure vs. Temperature (psi, water, non-shock)

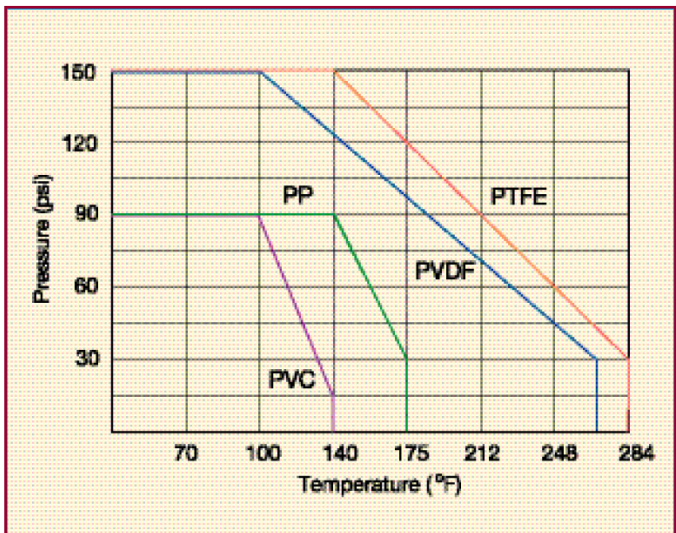

## Troubleshooting

### What if fluid flows even when fully closed?

1. Plug or seat is damaged. Change plug or seat.
2. Foreign matter caught or formed at plug and seat.
3. Air not completely exhausted.

### What if it does not open?

1. Actuator diaphragm is damaged or worn. Replace.
2. Operating air pressure is low.

### What if fluid leaks from body?

1. Bolts for bellows housing and body are loose. Retighten
2. O-ring(s) chemically attacked.

# Globe Control Valves

## Cv Values for PVC and PP

SEAT DIA. INCHES	VALVE SIZE (INCHES)								
	1/2	3/4	1	1-1/4	1-1/2	2	2-1/2	3	4
.106	.23	-	-	-	-	-	-	-	-
.149	.46	-	-	-	-	-	-	-	-
.185	.70	-	-	-	-	-	-	-	-
.236	1.20	-	-	-	-	-	-	-	-
.299	1.75	1.75	-	-	-	-	-	-	-
.374	2.60	2.60	2.6	-	-	-	-	-	-
.404	-	4.00	4.0	4.0	-	-	-	-	-
.578	-	6.10	6.1	6.1	6.1	-	-	-	-
.748	-	-	-	9.5	9.5	9.5	-	-	-
.944	-	-	-	10.5	10.5	10.5	10.5	-	-
1.181	-	-	-	-	16.0	16.0	16.0	16.0	-
1.496	-	-	-	-	-	25.0	25.0	25.0	25.0
1.909	-	-	-	-	-	-	40.0	40.0	40.0
2.047	-	-	-	-	-	-	46.0	46.0	46.0
2.244	-	-	-	-	-	-	-	64.0	64.0
2.696	-	-	-	-	-	-	-	-	81.0
2.897	-	-	-	-	-	-	-	-	93.0

## Cv Values for PVDF and PTFE

SEAT DIA. INCHES	VALVE SIZE (INCHES)								
	1/2	3/4	1	1-1/4	1-1/2	2	2-1/2	3	4
.106	.23	-	-	-	-	-	-	-	-
.149	.46	-	-	-	-	-	-	-	-
.185	.70	-	-	-	-	-	-	-	-
.236	1.20	-	-	-	-	-	-	-	-
.299	1.75	1.75	-	-	-	-	-	-	-
.374	2.60	2.60	2.6	-	-	-	-	-	-
.404	-	4.00	4.0	4.0	-	-	-	-	-
.578	-	6.10	6.1	6.1	6.1	-	-	-	-
.748	-	-	-	10.5	10.5	10.5	10.5	-	-
.944	-	-	-	-	14.0	14.0	14.0	14.0	-
1.181	-	-	-	-	18.0	18.0	18.0	16.0	16.0
1.496	-	-	-	-	-	29.0	29.0	29.0	29.0
1.909	-	-	-	-	-	-	40.0	40.0	40.0
2.047	-	-	-	-	-	-	-	52.0	52.0
2.244	-	-	-	-	-	-	-	-	70.0
2.696	-	-	-	-	-	-	-	-	93.0
2.897	-	-	-	-	-	-	-	-	105.0

## Required Data for Control Valve Sizing

SERVICE CONDITIONS			
1. Media			Concentration %
2. Temperature	°F	or	°C Specify
3. Flow Required (gpm):	Max.:	Normal	Min.
4. Line Pressure (psi):	Upstream:	Downstream:	(Max. Flow)
5	Upstream:	Downstream:	(Norm. Flow)
6	Upstream:	Downstream:	(Min. Flow)
VALVE SPECS			
7. Line Size:			
8. Valve Characteristics	Equal % or Linear:		Specify
9. Valve Material:			Valve Seals:
10. Cv Value Required	Max.:	Norm.:	Min.:
ACTUATOR SPECS			
11. Actuator Type:	Electric or Pneumatic		Specify
12. Supply Voltage for Electric:			Specify
13. Electric Control Signal:		mA or Volts	
14. Pneumatic Control Signal:		PSI	
15. Position Feedback:			Specify